

durELplex™ D504B Multi-Segment EL Driver IC

Features

- Quadruple 3P EL Lamp Driver
- EL Lamp Dimming and Regulation for Fading Effect and Constant Luminance between segments
- I2C Communication Capability
- Patented Low-Noise Wave-Shape
- Up to 3 ICs on a single bus for up to 12 outputs
- High Efficiency
- High Performance With Single Low-profile Coil
- Pb-free and Green QFN Package

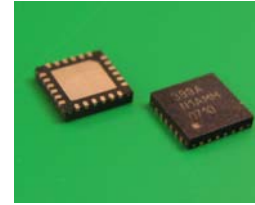

QFN-20

Rogers' DUREL® durELplex™ D504B EL driver is part of a family of highly integrated EL drivers based on Rogers' patented three-port (3P) topology, which offers built-in EMI shielding. This high-performance device drives up to 4 EL lamp segments using a proprietary circuit design to produce a low-noise wave shape for low-noise performance in applications that are sensitive to audible and electrical noise. Each segment is independently controlled through the I²C serial communication protocol.

Applications

- durELplex™ Multi-Segment EL Lamps
- DFLX® EL Keypad Lamps
- Decorative Lighting
- Data Organizers/PDAs
- Remote Controls

Lamp Driver Specifications:

(Using **Standard Test Circuit** shown in Figure 1 below at Ta=250°C unless otherwise specified. Specified values and ranges represent allowable product variability at standard test but overall functionality is not limited.)

Parameter	Symbol	Minimum	Typical*	Maximum	Units	Conditions
Standby Current	I _{v+}	0	10	1000	nA	E = GND
Supply Current	I	0	37	45	mA	E = 3.3V+
Output Voltage	V _{OUT}	170	190	220	V _{pp}	E = 3.3V+
Lamp Frequency	LF	280	300	350	Hz	CLF = 10nF
Inductor Frequency	HF	60	71	80	kHz	CHF = 220pF

*Typical values should not be used for specification limits

Standard Test Circuit

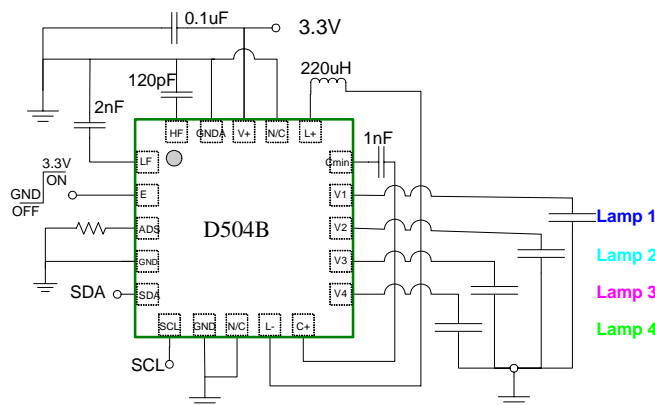
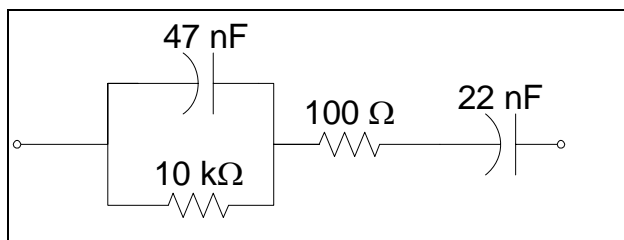

Figure 1 – Standard Test Circuit

The information contained in this data sheet is intended to assist you in designing with Rogers' EL systems. It is not intended to and does not create any warranties, express or implied, including any warranty of merchantability or fitness for a particular purpose or that the results shown on the data sheet will be achieved by a user for a particular purpose. The user should determine the suitability of Rogers' EL systems for each application.



*Load B approximates a 5in² (32.3cm²) EL lamp.

Figure 2 – Load B*

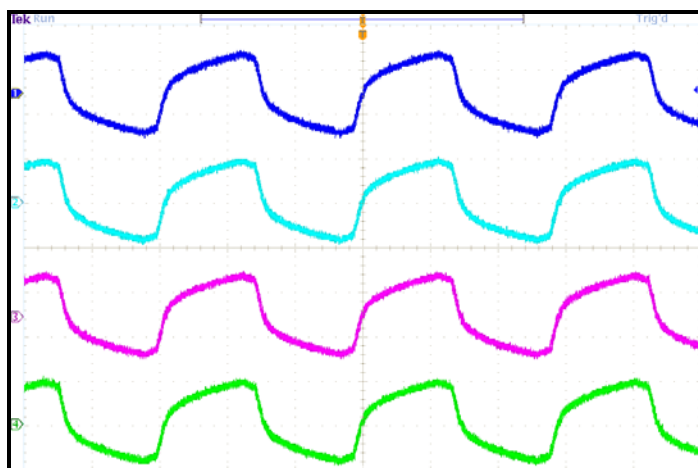

Figure 3 – Typical Output Waveforms

Absolute Maximum Ratings:

Parameter	Symbol	Minimum	Maximum	Unit	Comments
Supply Voltage Operating Range Withstand Range	V ₊	2.1 -0.4	5.0 5.0	V	E=V ₊ E=GND
Enable Voltage	E _{ON}		V ₊	V	
	E _{OFF}	-0.4			
Output Voltage	V _{OUT}		220	V _{pp}	Peak-to-Peak voltage
CHF Voltage	V _{CHF}	0	V ₊ +0.3	V	External Clock input
CLF Voltage	V _{CLF}	0	V ₊ +0.3	V	External Clock input
Operating Temperature	T _A	-40	85	°C	
Storage temperature	T _S	-55	150	°C	
Lamp series resistance	R _{LAMP}			Ohm	

Note: The above table reflects stress ratings only. Functional operation of the device at these ratings or any other above those indicated in the specification is not implied. Exposure to absolute maximum rating conditions for extended periods of time may affect reliability.

The information contained in this data sheet is intended to assist you in designing with Rogers' EL systems. It is not intended to and does not create any warranties, express or implied, including any warranty of merchantability or fitness for a particular purpose or that the results shown on the data sheet will be achieved by a user for a particular purpose. The user should determine the suitability of Rogers' EL systems for each application.

Physical Data:

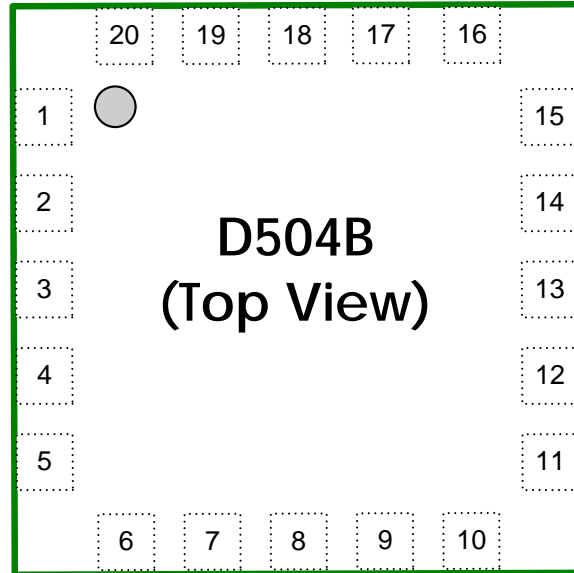

Figure 4 – D504B Package Outline

Table 1 – Pin Description

PIN#	NAME	FUNCTION
1	CLF	Lamp frequency capacitor/clock input
2	E	System enable
3	ADS	I2C address select
4	GND	System ground connection
5	SDA	I2C serial data I/O
6	SCL	I2C serial clock I/O
7	GND	System ground connection
8	N/C	No Connect, recommend ground
9	L-	Negative input to inductor
10	C+	Over voltage protection capacitor positive connection
11	Vout4	High voltage AC output to lamp
12	Vout3	High voltage AC output to lamp
13	Vout2	High voltage AC output to lamp
14	Vout1	High voltage AC output to lamp
15	C-	Over voltage protection cap negative connection
16	L+	Positive input to inductor
17	N/C	No Connect, recommend ground
18	Vcc	DC power supply input
19	GNDA	Analog ground connection
20	CHF	High frequency oscillator capacitor/clock input

The information contained in this data sheet is intended to assist you in designing with Rogers' EL systems. It is not intended to and does not create any warranties, express or implied, including any warranty of merchantability or fitness for a particular purpose or that the results shown on the data sheet will be achieved by a user for a particular purpose. The user should determine the suitability of Rogers' EL systems for each application.

Typical Performance Characteristics

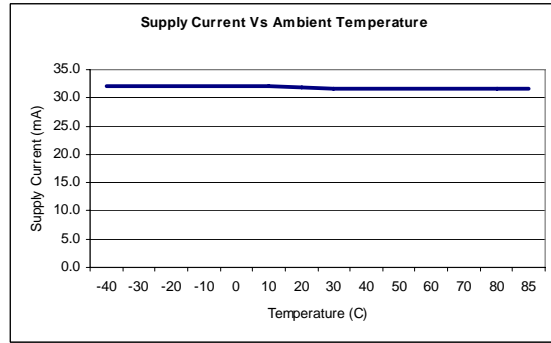
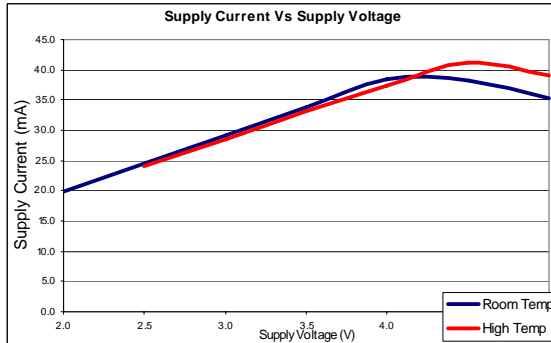
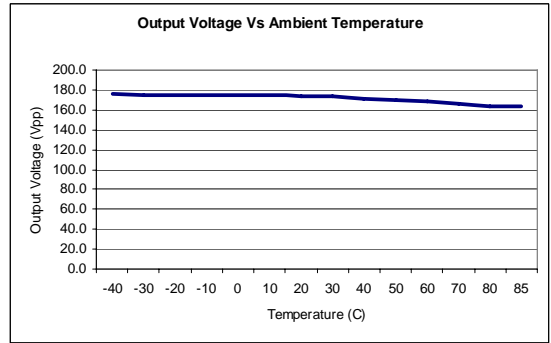
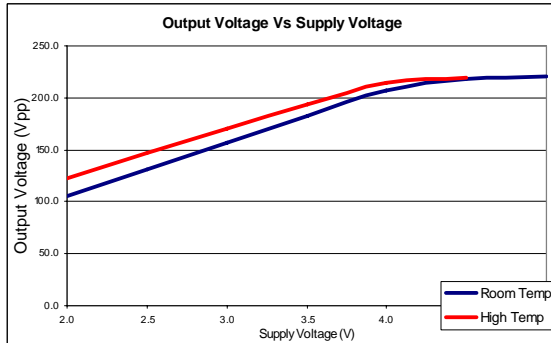
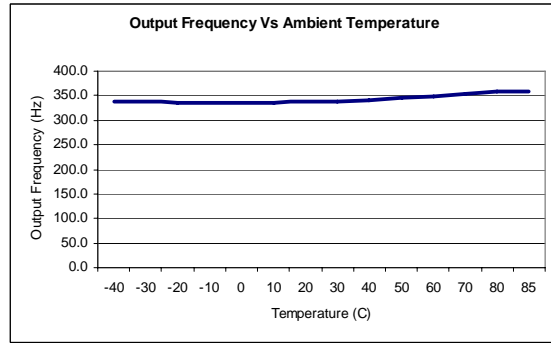
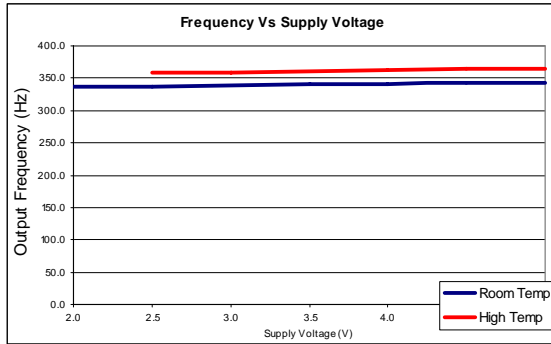

The information contained in this data sheet is intended to assist you in designing with Rogers' EL systems. It is not intended to and does not create any warranties, express or implied, including any warranty of merchantability or fitness for a particular purpose or that the results shown on the data sheet will be achieved by a user for a particular purpose. The user should determine the suitability of Rogers' EL systems for each application.

Block Diagram of the Driver Circuitry

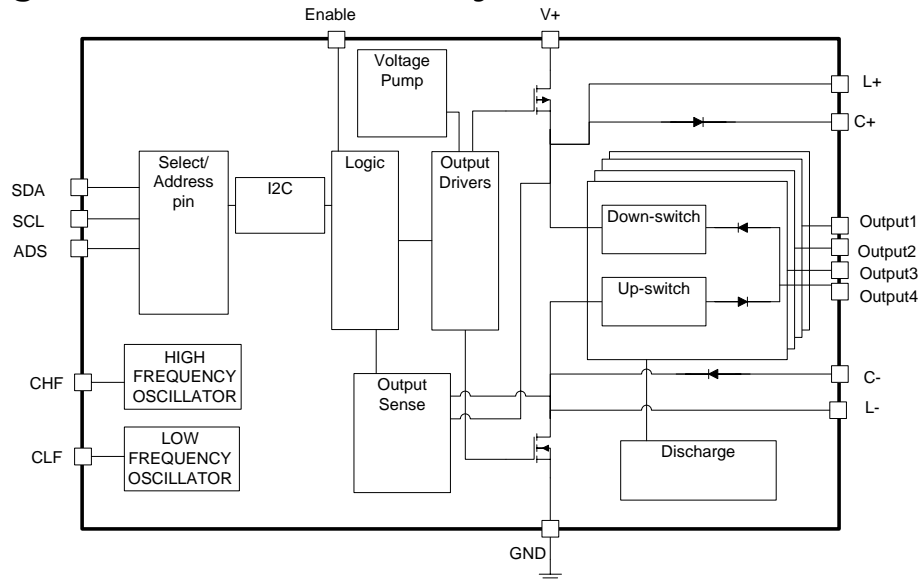

Theory of Operation

Electroluminescent (EL) lamps are essentially capacitors with one transparent electrode and a special phosphor material in the dielectric. The phosphor glows when a strong AC voltage is applied across the EL lamp electrodes. The required AC voltage is typically not present in most systems and must be generated from a low voltage DC source. Rogers developed its patented three-port (3P) switch-mode inverter circuit to convert the available DC supply to an optimal drive signal for high brightness and low-noise EL lamp applications. Rogers' 3P topology offers the simplicity of a single DC input, single AC output, and a shared common ground that provides integrated EMI shielding.

The durELplex D504B IC drives the EL lamp by repeatedly pumping charge through an external inductor with current from a DC source and discharging into the capacitance of the EL lamp load. The voltage on the lamp increases with each high frequency (HF) cycle. At a period specified by the lamp frequency (LF) oscillator, the voltage on the lamp is discharged to ground and the polarity of the inductive charging is reversed. By this means, an alternating positive and negative voltage is developed at the single output lead of the device to one of the electrodes of the EL lamp. The other lamp electrode is commonly connected to a ground plane, which can then be considered as electrical shielding for any underlying circuitry in the application.

The EL driving system is divided into several parts: on-chip logic and control, on-chip high voltage output circuitry, discharge logic circuitry, and off-chip components. The on-chip logic controls the lamp operating frequency (LF), as well as the inductor switching frequency (HF), and HF and LF duty cycles. These signals are combined and buffered to regulate the high voltage output circuitry. The output circuitry handles the power through the inductor and delivers the high voltage to the lamp. The integrated discharge logic circuit enables the low-noise functionality of this EL driver with two levels

The information contained in this data sheet is intended to assist you in designing with Rogers' EL systems. It is not intended to and does not create any warranties, express or implied, including any warranty of merchantability or fitness for a particular purpose or that the results shown on the data sheet will be achieved by a user for a particular purpose. The user should determine the suitability of Rogers' EL systems for each application.

of discharge on the output waveform. The selection of off-chip components provides a degree of flexibility to accommodate various lamp sizes, system voltages, and brightness levels. As a key objective for EL driver systems is to save space and cost, required off-chip components are kept to a minimum.

Rogers provides a D504B IC Designer's Kit, which includes a printed circuit evaluation board intended to aid you in developing an EL lamp driver configuration that meets your requirements using the D504B IC. A section on designing with the D504B IC is included in this datasheet to serve as a guide to help you select the appropriate external components to complete your D504B EL driver system.

Reference D504B EL Driver Configurations:

Typical D504B IC configurations for driving EL lamps in various applications are shown below. The expected system outputs, such as lamp luminance, lamp output frequency and voltage and average supply current draw for the various sample configurations are also shown with each respective figure.

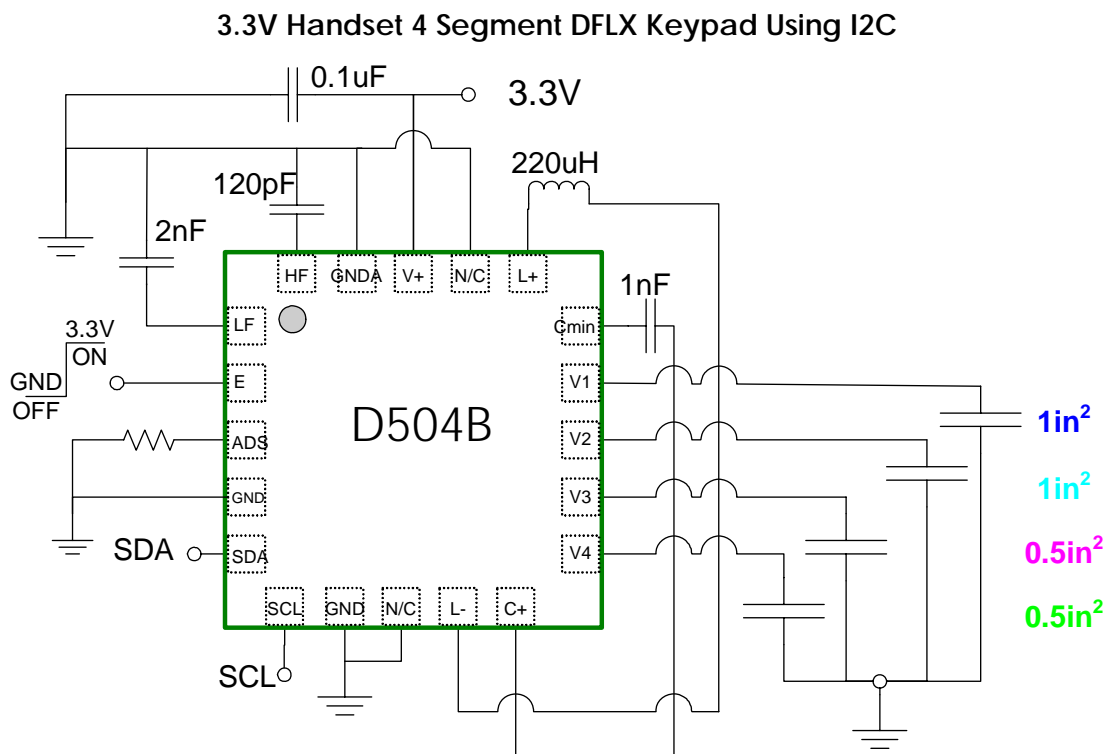

Typical Output

Luminance = 20cd/m²
 Lamp Frequency = 293Hz
 Supply Current = 40mA
 Vout = 203Vpp
 Load: 3.3in² Total Lit Area

Example I2C Serial Data:

Hex - (60)(00)(1F)(1F)(1F)(01)

(IC Address)(Output Sub-Address)(Data V1)
 (Data V2)(Data V3)(Data V4)(Enable Register)

The information contained in this data sheet is intended to assist you in designing with Rogers' EL systems. It is not intended to and does not create any warranties, express or implied, including any warranty of merchantability or fitness for a particular purpose or that the results shown on the data sheet will be achieved by a user for a particular purpose. The user should determine the suitability of Rogers' EL systems for each application.

3.3V Handset 12 Segment DFLX Keypad Using I2C

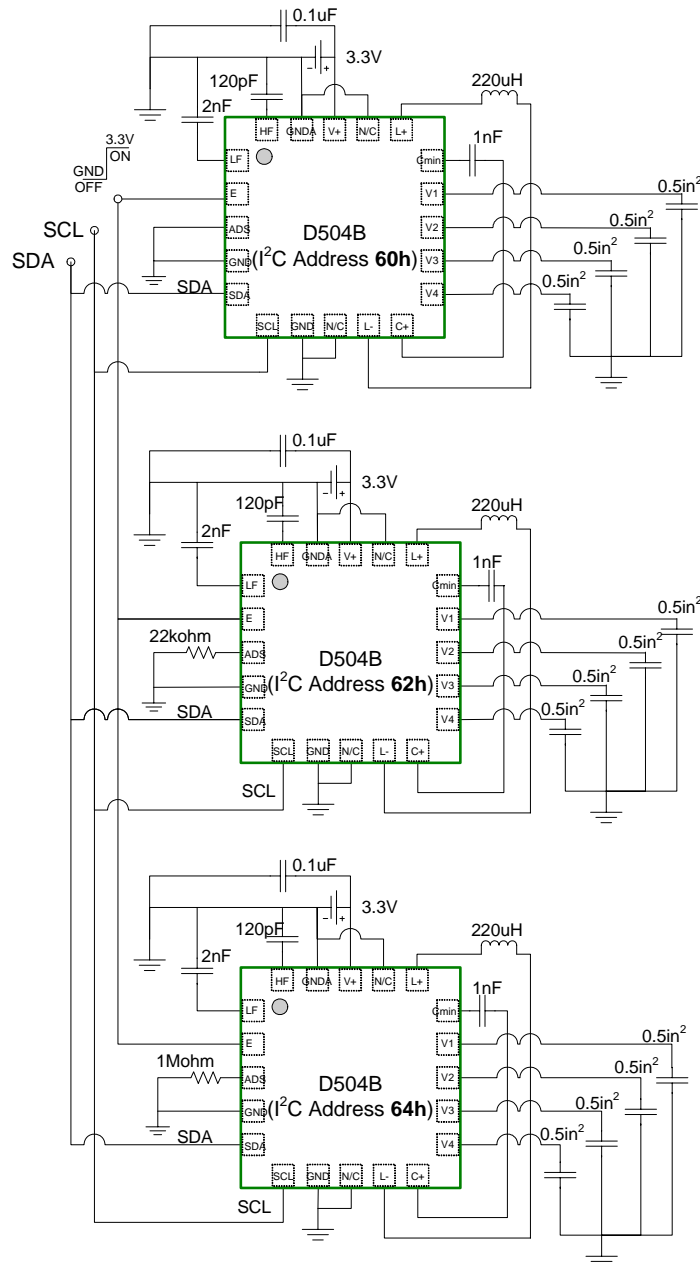

Typical Output

Luminance = tbd
 Lamp Frequency = tbd
 Supply Current = tbd
 Vout = tbd
 Load: 3in² Total Lit Area

Example I2C Serial Data:

Hex - (60)(00)(1F)(1F)(1F)(1F)(01)

Hex - (62)(00)(1F)(1F)(1F)(1F)(01)

Hex - (64)(00)(1F)(1F)(1F)(1F)(01)

(IC Address)(Output Sub-Address)(Data V1)
 (Data V2)(Data V3)(Data V4) (Enable Register)

The information contained in this data sheet is intended to assist you in designing with Rogers' EL systems. It is not intended to and does not create any warranties, express or implied, including any warranty of merchantability or fitness for a particular purpose or that the results shown on the data sheet will be achieved by a user for a particular purpose. The user should determine the suitability of Rogers' EL systems for each application.

Designing With A D504B EL Driver IC:

I. Lamp Frequency Capacitor (CLF) Selection

Selecting the appropriate value of lamp frequency capacitor (CLF) for the low frequency oscillator will specify the output frequency of the D504B EL driver. Lamp frequencies of 200-500Hz are typically used. Figure 5 graphically represents the inversely proportional relationship between the CLF capacitor value and the oscillator frequency.

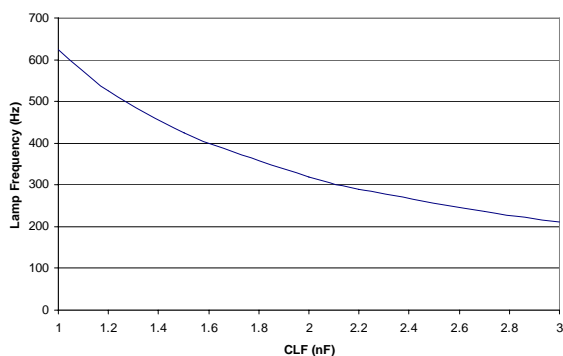

Figure 5—Typical lamp frequency vs. CLF capacitor

Alternatively, the lamp frequency may also be controlled with an external clock signal. There is an internal frequency divider in the device so that the output lamp frequency will be one-sixteenth (6.25%) of the input clock signal. For example, if a 3.2 kHz input clock signal is used the resulting lamp frequency will be 200Hz. The clock signal input voltage should not exceed V_+ .

The selection of the CLF value can also affect the brightness of the EL lamp because of its control of the lamp frequency (LF). Although input voltage and lamp size can have a small impact on the EL lamp frequency, LF mainly depends on the CLF value selected or the frequency of the input clock signal to CLF. Figure 6 shows typical brightness of a D504B IC circuit with respect to lamp frequency. In this example, the inductor and CHF values were kept constant while varying LF.

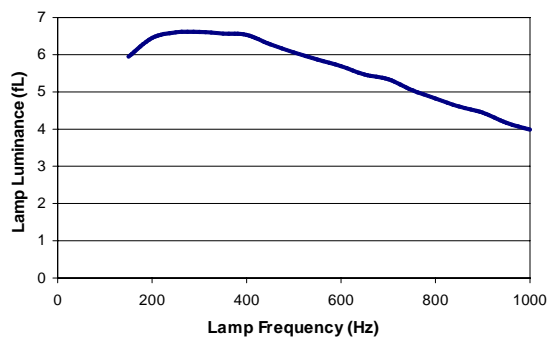

Figure 6— Luminance vs. lamp frequency
($V_+ = 3.0V$, 2.4 in² DUREL 3 Green EL Lamp Load)

The information contained in this data sheet is intended to assist you in designing with Rogers' EL systems. It is not intended to and does not create any warranties, express or implied, including any warranty of merchantability or fitness for a particular purpose or that the results shown on the data sheet will be achieved by a user for a particular purpose. The user should determine the suitability of Rogers' EL systems for each application.

II. High Frequency Capacitor (CHF) Selection

Selecting the appropriate value of capacitor for the high frequency oscillator (CHF) will set the inductor switching frequency of the D504B IC. High inductor frequency allows for more efficient use of inductor coils with lower values. However, care must be taken to insure that the charge pumping does not reach a continuous mode at very high frequency where the voltage is not efficiently transferred to the lamp load. Figure 7 graphically represents the effect of the CHF value on the oscillator frequency at $V_+ = 3.0V$.

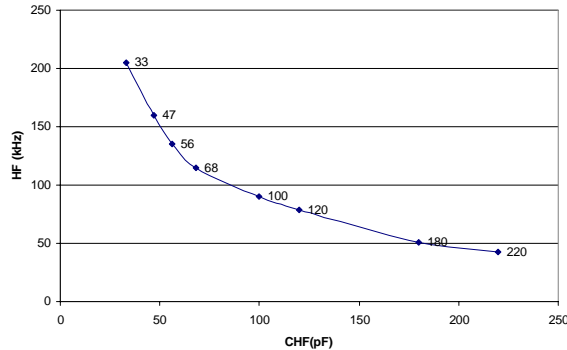

Figure 7—Typical inductor frequency vs. CHF capacitor

The inductor switching frequency may also be controlled with an external clock signal. The inductor will charge during the low portion of the clock signal and discharge into the EL lamp during the high portion of the clock signal. The positive duty cycle used for the external high frequency clock signal is usually between 15%-75%, with a typical value of 15%-20% for maximum brightness. The clock signal input voltage should not exceed V_+ .

V. D504B IC Operating Considerations

The following recommendations should be considered when testing the D504B IC device to ensure that the devices are not damaged.

Prevent voltage spikes at V_+ . Place the V_+ decoupling capacitor close to the IC. Avoid long wires from the V_+ power supply to the IC in the test environment.

The information contained in this data sheet is intended to assist you in designing with Rogers' EL systems. It is not intended to and does not create any warranties, express or implied, including any warranty of merchantability or fitness for a particular purpose or that the results shown on the data sheet will be achieved by a user for a particular purpose. The user should determine the suitability of Rogers' EL systems for each application.

D504B IC Design Ideas:

I. Theater Lighting Fade ON Fade OFF Output Control

EL lamp fading can be performed via I2C serial communication. Each output segment can be controlled independently for desired level of luminance. Continually fading on and off a segment will result in a throbbing (breathing) effect.

Example 1: Fade Off All Segments Simultaneously

I2C Standard Communication

(60)(00)(1F)(1F)(1F)(1F)(01)

(60)(00)(1E)(1E)(1E)(1E)

(60)(00)(1D)(1D)(1D)(1D)

.....

(60)(00)(00)(00)(00)(00)

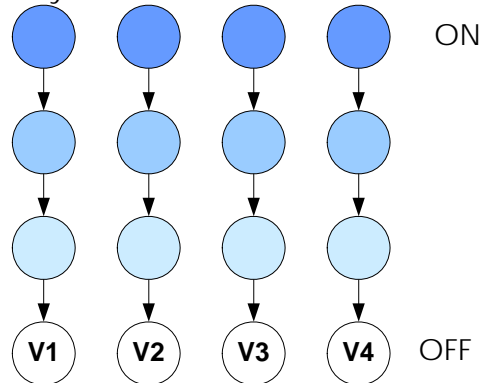

Example 2: Fade On V3 and V4 Segments only

I2C Standard Communication

(60)(00)(00)(00)(00)(00)(01)

(60)(00)(00)(00)(01)(01)

(60)(00)(00)(00)(02)(02)

.....

(60)(00)(00)(00)(1F)(1F)

I2C Sub-Address Communication

(60)(00)(00)(00)(00)(00)(01)

(60)(02)(01)(01)

(60)(02)(02)(02)

.....

(60)(02)(1F)(1F)

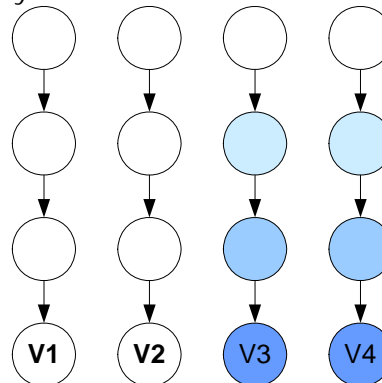

The information contained in this data sheet is intended to assist you in designing with Rogers' EL systems. It is not intended to and does not create any warranties, express or implied, including any warranty of merchantability or fitness for a particular purpose or that the results shown on the data sheet will be achieved by a user for a particular purpose. The user should determine the suitability of Rogers' EL systems for each application.

II. Flashing EL Lamps

EL lamp flashing can be performed via I2C serial communication. Each output segment can be controlled independently to perform synchronized flashing such as blinking on and off, chasing lights, or programmed chorography

Example 1: Alternating flash

I2C Standard Communication

(60)(00)(1F)(00)(1F)(00)(01)

(60)(00)(00)(1F)(00)(1F)

(60)(00)(1F)(00)(1F)(00)

(60)(00)(00)(1F)(00)(1F)

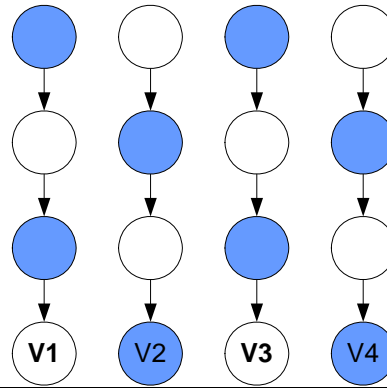

Example 2: Chasing flash

I2C Standard Communication

(60)(00)(1F)(00)(00)(00)(01)

(60)(00)(00)(1F)(00)(00)

(60)(00)(00)(00)(1F)(00)

(60)(00)(00)(00)(00)(1F)

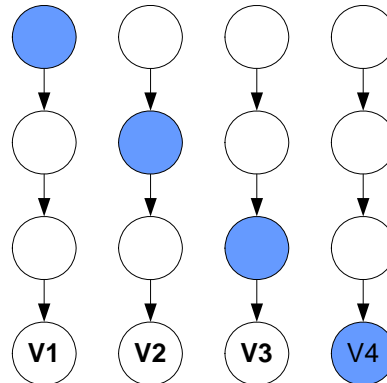

I2C Sub-Address Communication

(60)(00)(1F)(00)(00)(00)(01)

(60)(01)(00)(1F)

(60)(02)(00)(1F)

(60)(03)(00)(1F)

The information contained in this data sheet is intended to assist you in designing with Rogers' EL systems. It is not intended to and does not create any warranties, express or implied, including any warranty of merchantability or fitness for a particular purpose or that the results shown on the data sheet will be achieved by a user for a particular purpose. The user should determine the suitability of Rogers' EL systems for each application.

III. Synthesizer EL Lamps

EL lamp cross-fading can be performed via I2C serial communication. Each output segment can be dimmed in sequence such that the synchronized dimming appears to be synthesized.

Example 1: Synthesizer

I2C Standard Communication

(60)(00)(1F)(00)(1F)(00)(01)

(60)(00)(1E)(01)(1E)(01)

(60)(00)(1D)(02)(1D)(02)

.....

(60)(00)(00)(1F)(00)(1F)

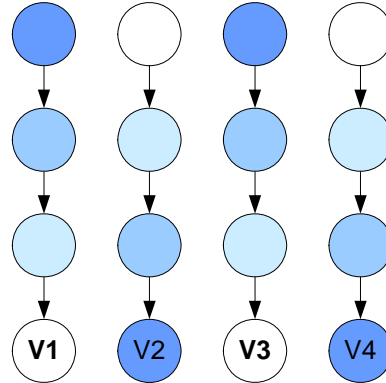

Digital Selective Enable / Disable

The D504B IC is designed to have minimal standby current. The enable pin is used as the master to enable the EL driver, the serial interface, and the digital controller. The enable register is used to put the IC in standby mode and is controlled via the I2C serial data. The last byte of data can be used to enable or disable the enable register.

Enable Pin	Enable Register	Serial Interface	Digital Controller
0	X	OFF	OFF
1	0	ON	OFF
1	1	ON	ON

I2C Address Selection

The D504B IC is designed to be compatible with standard I2C serial communication. Using the address (ADS) pin, the EL driver can have up to three I2C addresses.

Address Resistor (Ohm)	A0	A1	Mode
0	0	0	I2C mode with address 60h
22k	1	0	I2C mode with address 62h
1M	0	1	I2C mode with address 64h

I2C Bus Protocol

The D504B is designed to be compatible with standard I2C protocol. The EL driver operates in slave mode only. The EL driver supports I2C fast mode (400kHz) and standard mode (100kHz). After a start condition (S), a valid address has to be sent to the D504B (60h, 62h, or 64h) followed by a sub-address (00h, 01h, 02h, 03h, 04h) and n

The information contained in this data sheet is intended to assist you in designing with Rogers' EL systems. It is not intended to and does not create any warranties, express or implied, including any warranty of merchantability or fitness for a particular purpose or that the results shown on the data sheet will be achieved by a user for a particular purpose. The user should determine the suitability of Rogers' EL systems for each application.

data bytes (00h to 1Fh). The sub-address sets the designated output register for the following n data bytes. After the sub-address data bytes are sent, the sub-address is incremented automatically. After all data bytes have been transferred, a stop condition is needed (P). Each data byte is followed by an acknowledge bit.



Data Byte Definition

The following tables show the data byte definition. These data bytes are to control the brightness level of each output segment. The hex bit values “0” to “1F” correspond to lowest brightness level to highest brightness level.

If the desired output is to have Vout1 at maximum luminance while all other outputs are off, then sub-address 00h would be set to 1Fh, while sub-addresses 01h, 02h and 03h would be set to 00h.

Sub-address	7	6	5	4	3	2	1	0
00h	X	X	X	Vout1 Bit 4	Vout1 Bit 3	Vout1 Bit 2	Vout1 Bit 1	Vout1 Bit 0
01h	X	X	X	Vout2 Bit 4	Vout2 Bit 3	Vout2 Bit 2	Vout2 Bit 1	Vout2 Bit 0
02h	X	X	X	Vout3 Bit 4	Vout3 Bit 3	Vout3 Bit 2	Vout3 Bit 1	Vout3 Bit 0
03h	X	X	X	Vout4 Bit 4	Vout4 Bit 3	Vout4 Bit 2	Vout4 Bit 1	Vout4 Bit 0
04h	X	X	X	X	X	X	X	Controller Enable

The data and enable registers’ default values are shown below. All outputs are default to zero volts and the digital controller is on leaving the IC in standby mode.

Register (Sub-Address)	7	6	5	4	3	2	1	0
Vout1 (00h)	0	0	0	0	0	0	0	0
Vout2 (01h)	0	0	0	0	0	0	0	0
Vout3 (02h)	0	0	0	0	0	0	0	0
Vout4 (03h)	0	0	0	0	0	0	0	0
Enable (04h)	0	0	0	0	0	0	0	1

The information contained in this data sheet is intended to assist you in designing with Rogers’ EL systems. It is not intended to and does not create any warranties, express or implied, including any warranty of merchantability or fitness for a particular purpose or that the results shown on the data sheet will be achieved by a user for a particular purpose. The user should determine the suitability of Rogers’ EL systems for each application.

Solder Re-Flow Recommendations

Classification Reflow Profiles

Profile Feature	Pb-Free Assembly 1DDD504BB-P06
Average ramp-up rate (T_L to T_P)	3°C/second max.
Preheat	
-Temperature Min (T_{smin})	150°C
-Temperature Max (T_{smax})	200°C
-Time (min to max) (ts)	60-180 seconds
T_{smax} to T_L	
-Ramp-up Rate	3°C/second max.
Time maintained above: Temperature (T_L)	217°C
-Time (T_L)	60-150 seconds
Peak Temperature (T_P)	250 +0/-5°C
Time within 5°C of actual Peak Temperature (T_P)	20-40 seconds
Ramp-down Rate	
Time 25°C to Peak	6°C/second max.
Temperature	8 minutes max.

IPC/JEDEC J-STD-020B

July 2002

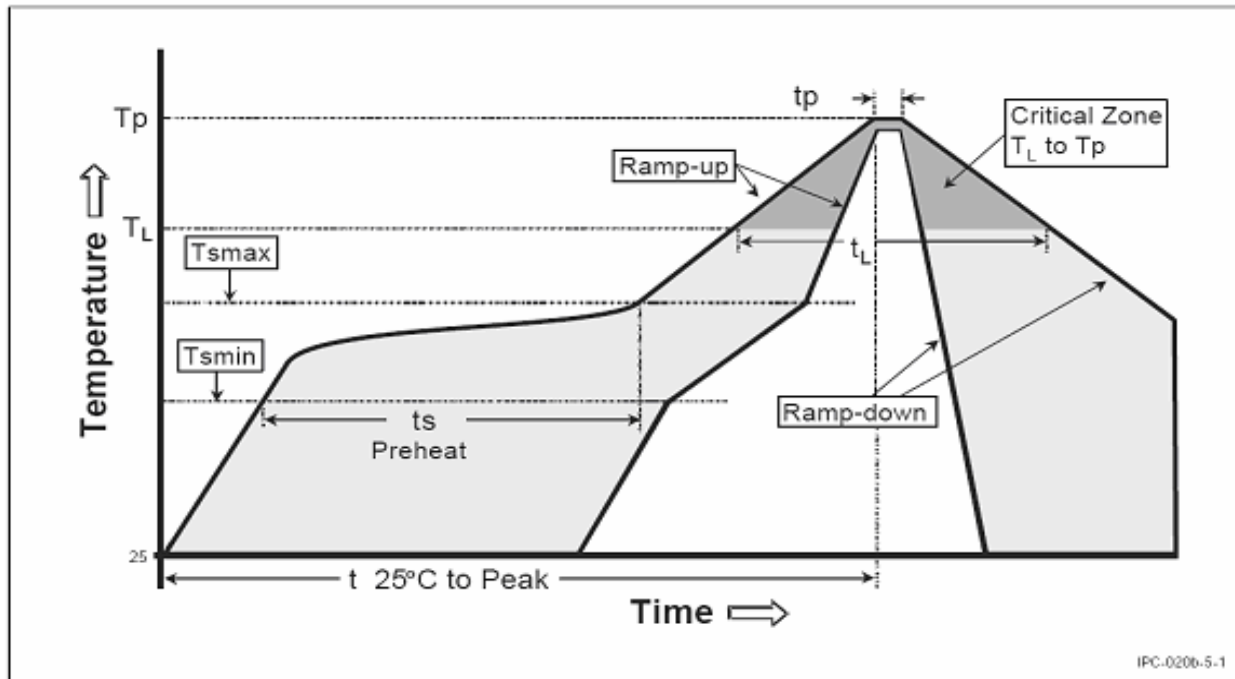

Figure 5-1 Classification Reflow Profile

Note: All Temperatures refer to topside of the package, measured on the package body surface
 Note: All Temperatures refer to IPC/JEDEC J-STD-020B

The information contained in this data sheet is intended to assist you in designing with Rogers' EL systems. It is not intended to and does not create any warranties, express or implied, including any warranty of merchantability or fitness for a particular purpose or that the results shown on the data sheet will be achieved by a user for a particular purpose. The user should determine the suitability of Rogers' EL systems for each application.

Ordering Information

Rogers' Part Number 1DDD504BB-P06 for product to be shipped in QFN-20 plastic thermal enhanced quad flat package in embossed tape on 360mm diameter reel.

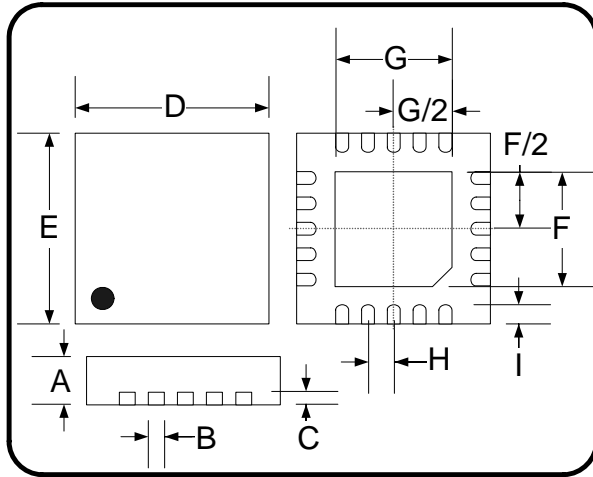

QFN-20 DIMENSIONS						
	Min		Nominal		Max	
	mm	in	mm	in	mm	in
A	0.700	0.0270	0.750	0.029	0.800	0.0310
B	0.180	0.0070	0.230	0.009	0.300	0.0120
C			0.203	0.008		
D	3.925	0.1540	4.000	0.157	4.075	0.1600
E	3.925	0.1540	4.000	0.157	4.075	0.1600
F	0.75	0.0290	1.700	0.0670	2.250	0.0880
G	0.75	0.0290	1.700	0.0670	2.250	0.0880
H			0.500	0.0200		
I	0.350	0.0140	0.550	0.0210	0.750	0.0290

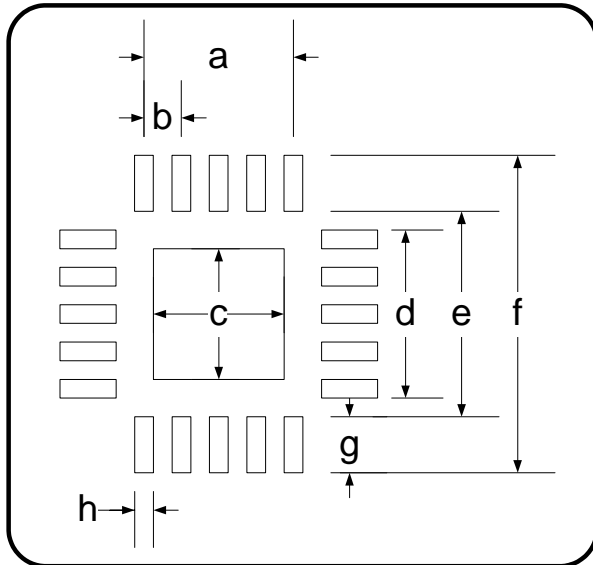

QFN-20 PAD LAYOUT DIMENSIONS						
	Min		Nominal		Max	
	mm	in	mm	in	mm	in
a			2.00	0.080		
b			0.50	0.020		
c	2.40	0.094	2.45	0.096	2.50	0.098
d	2.20	0.086	2.25	0.088	2.30	0.090
e	3.05	0.120	3.10	0.122	3.15	0.124
f	4.45	0.175	4.50	0.177	4.55	0.179
g	0.65	0.025	0.70	0.027	0.75	0.029
h	0.20	0.007	0.25	0.009	0.30	0.011

The information contained in this data sheet is intended to assist you in designing with Rogers' EL systems. It is not intended to and does not create any warranties, express or implied, including any warranty of merchantability or fitness for a particular purpose or that the results shown on the data sheet will be achieved by a user for a particular purpose. The user should determine the suitability of Rogers' EL systems for each application.

D504B in Tape & Reel: 1DDD504BB-P06

Embossed tape on 360 mm diameter reel.
2500 units per reel. Quantity marked on
reel label.

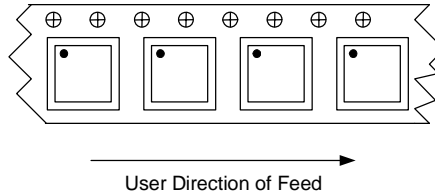

ISO 9001:2000, ISO/TS 16949:2002, and ISO 14001:1996 Certified

The information contained in this data sheet is intended to assist you in designing with Rogers EL systems. It is not intended to and does not create any warranties, express or implied, including any warranty of merchantability or fitness for a particular purpose or that the results shown on the data sheet will be achieved by a user for a particular purpose. The user should determine the suitability of Rogers' EL systems for each application.

The world runs better with Rogers. and the Rogers' logo are licensed trademarks of Rogers Corporation
DUREL, durELplex and DFLX are licensed trademarks of Rogers Corporation

©2008, 2009 Rogers Corporation. Printed in U.S.A

The world runs better with Rogers.®

All Rights Reserved

Revised 3/2009 Publication #LIT-I9081 A02
