

D381B Module Electroluminescent Lamp Driver IC

Features

- Turn-key solution
- Integrated external components
- Low Profile Leadless Package
- Small Footprint
- Lead-Free (Pb-free) and Green
- Integrated Low Noise Circuitry
- High Efficiency
- High Voltage AC Output

Applications

- Cellular Phones and Handsets
- Data Organizers/PDAs
- Monochrome LCDs
- Remote Controls
- DFLX™ EL Keypad Lamps



Rogers DUREL® D381B IC module is part of a family of highly integrated EL drivers based on Rogers' patented three-port (3P) topology, which offers built-in EMI shielding. This high-performance device uses a proprietary circuit design for low-noise performance in applications that are sensitive to audible and electrical noise. The module offers a fully integrated EL driver with a low profile and a small footprint.

Lamp Driver Specifications:

(Using Standard Test Circuit at Ta=25°C unless otherwise specified. Specified values and ranges represent allowable product variability at standard test but overall functionality is not limited.)

Parameter	Symbol	Minimum	Typical	Maximum	Unit	Conditions
Standby Current			10	1000	nA	E = 0V
Supply Current	I	20	25	30	mA	E = 3.3V
Enable Current	V _{OUT}		29		uA	E = 3.3V
Output Voltage	V _{out}	180	200	210	V _{pp}	E = 3.3V
Lamp Frequency	LF	330	415	500	Hz	
Inductor Frequency	HF		125		kHz	

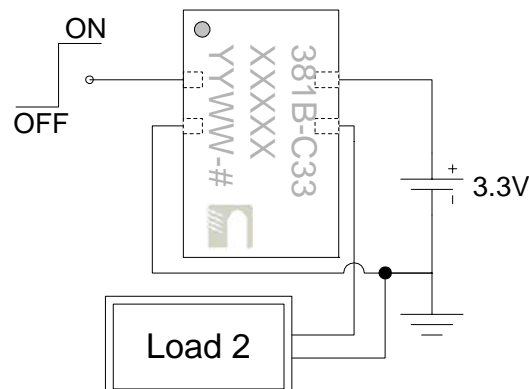

Load 2*

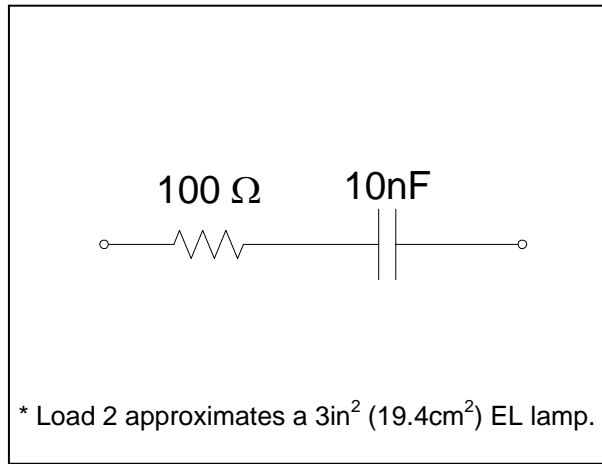

Typical Output Waveform

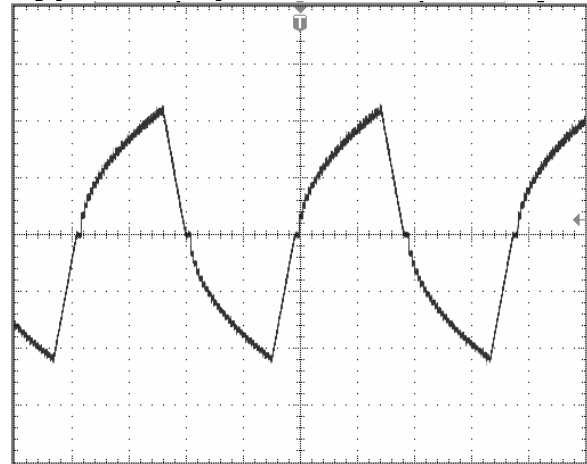

Absolute Maximum Ratings:

Parameter	Symbol	Minimum	Maximum	Unit	Comments
Supply voltage Operating Range Withstand Range	V+	2.0 -0.4	6.0 6.0	V	E = V+ E = GND
Enable voltage Enable on Enable off	E E _{ON} E _{OFF}	-0.4 2.0	V+ 0.7	V	
Output Voltage	V _{OUT}		220	V _{pp}	Peak-to-peak Voltage
Operating temperature	T _a	-40	85	°C	
Storage temperature	T _s	-65	150	°C	
Lamp Resistance	R _{lamp}	100		Ohm	

Note: The above table reflects ratings only. Functional operation of the device at these ratings or any other above those indicated in the specifications is not implied. Exposure to absolute maximum rating conditions for extended periods of time may affect reliability.

Physical Data:

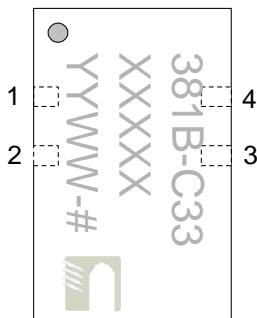

PIN #	NAME	FUNCTION
1	E	System enable
2	GND	System ground connection
3	VOOUT	High voltage AC output to lamp
4	V+	DC power supply input

Typical Performance Characteristics with DUREL Green EL Lamp Load

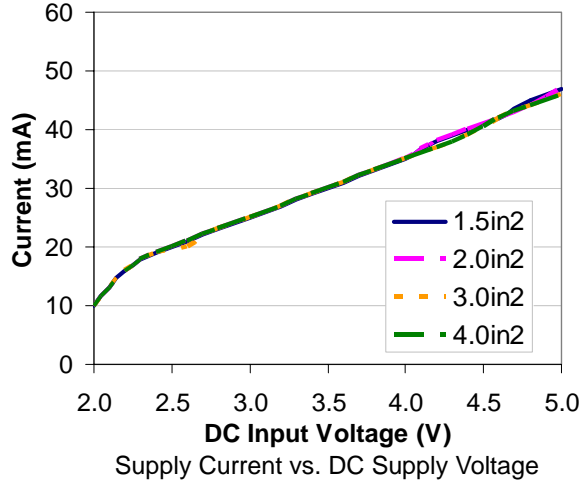
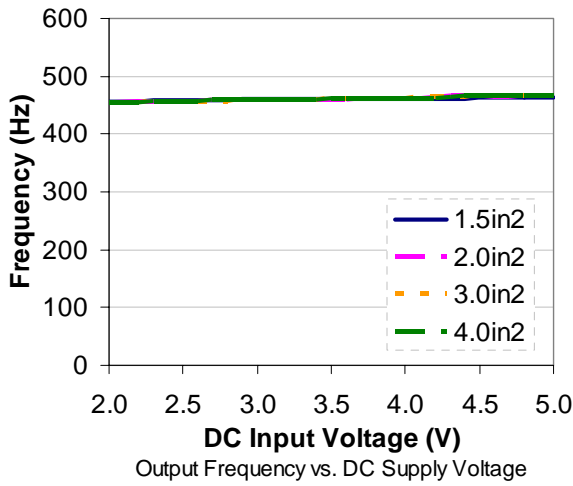
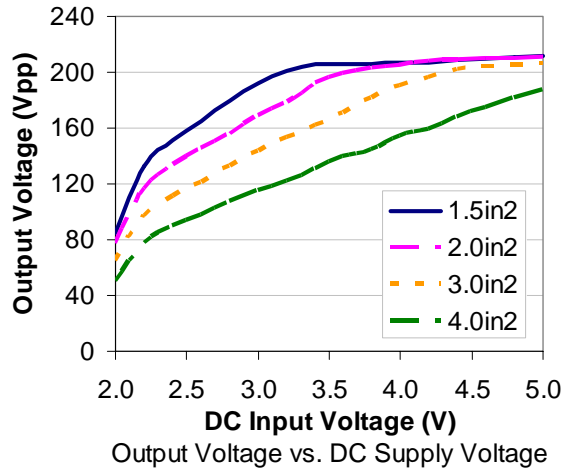

Typical Performance Characteristics

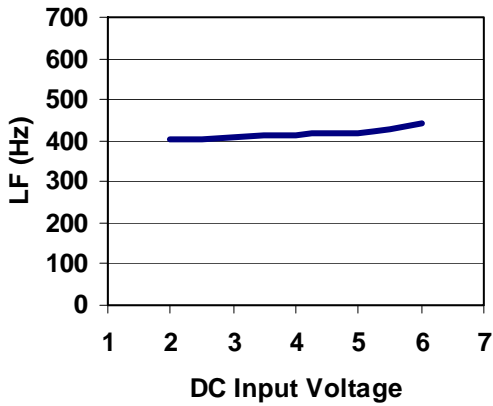

Output Frequency vs. DC Supply Voltage

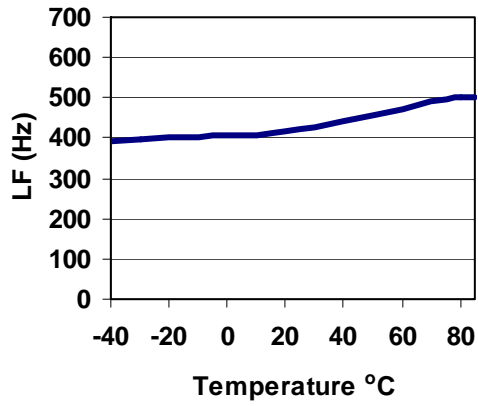

Output Frequency vs. Ambient Temperature

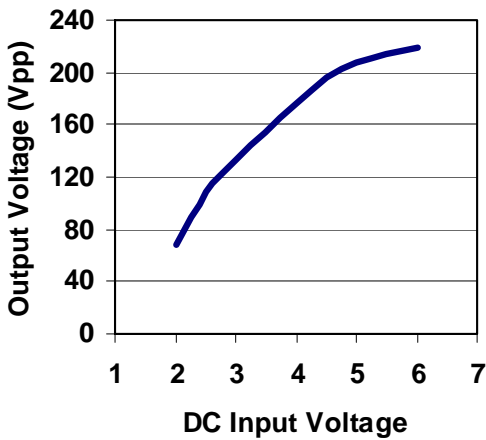

Output Voltage vs. DC Supply Voltage

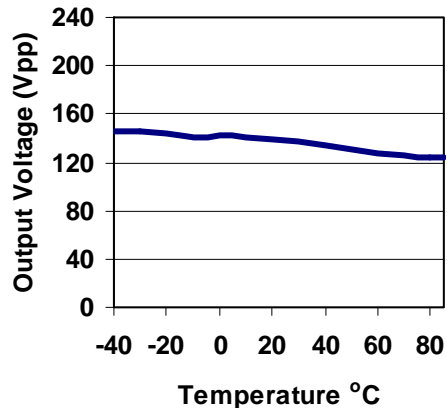

Output Voltage vs. Ambient Temperature

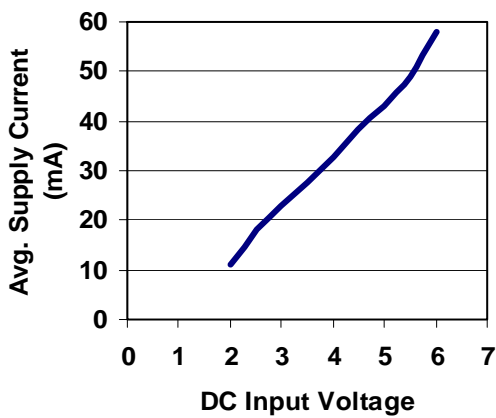

Supply Current vs. DC Supply Voltage

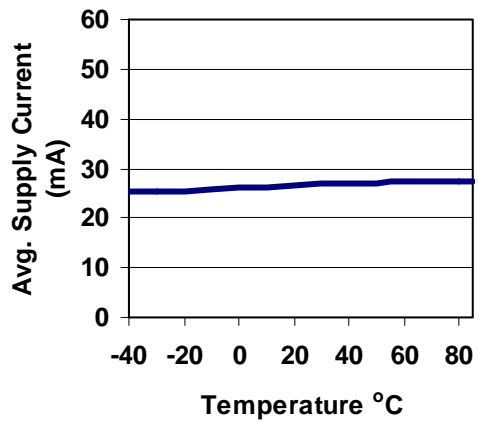

Supply Current vs. Ambient Temperature

Note: Load B used to obtain wider statistical measurements.

Block Diagram of the Inverter Circuitry

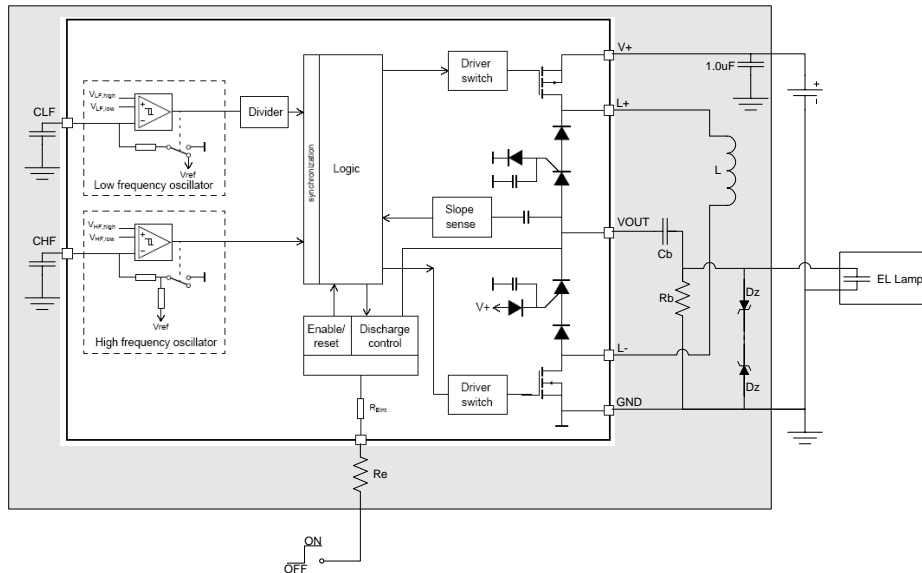

Theory of Operation

Electroluminescent (EL) lamps are essentially capacitors with one transparent electrode and a special phosphor material in the dielectric. The phosphor glows when a strong AC voltage is applied across the EL lamp electrodes. The required AC voltage is typically not present in most systems and must be generated from a low voltage DC source. Thus, Rogers developed its patented three-port (3P) switch-mode inverter circuit to convert the available DC supply to an optimal drive signal for high brightness and low-noise EL lamp applications. The Rogers 3P topology offers the simplicity of a single DC input, single AC output, and a shared common ground that provides an integrated EMI shielding.

The D381B IC module drives the EL lamp by repeatedly pumping charge through an external inductor with current from a DC source and discharging into the capacitance of the EL lamp load. With each high frequency (HF) cycle the voltage on the lamp is increased. At a period specified by the lamp frequency (LF) oscillator, the voltage on the lamp is discharged to ground and the polarity of the inductive charging is reversed. By this means, an alternating positive and negative voltage is developed at the single output lead of the device to one of the electrodes of the EL lamp. The other lamp electrode is commonly connected to a ground plane, which can then be considered as electrical shielding for any underlying circuitry in the application.

The EL driving system is divided into several parts: on-chip logic and control, on-chip high voltage output circuitry, discharge logic circuitry, and off-chip components. The on-chip logic controls the lamp operating frequency (LF), as well as the inductor switching frequency (HF), and HF and LF duty cycles. These signals are combined and buffered to regulate the high voltage output circuitry. The output circuitry handles the power through the inductor and delivers the high voltage to the lamp. The integrated discharge logic circuit enables the low-noise functionality of this EL driver with four levels of discharge slopes on the output waveform. Since a key objective for EL driver systems is to save space and cost, required off-chip components were integrated into the module.

A high pass filter has also been integrated into the module package to eliminate DC bias voltage from the vout. The bias capacitor and bias resistor have been selected such that the time constant is less than 4.7s.

Zener diode clamping has been implemented between the Vout pin and GND. Back-to-back 100V zener diodes are used. This regulates the output voltage of the module and prevents the voltage from exceeding 220Vpp.

Rogers provides a D381B Module IC Designer's Kit, which includes a printed circuit evaluation board intended to aid you in developing an EL lamp driver configuration that meets your requirements.

D381B Module Design

I. Enable Voltage Selection

The D381B IC module requires a minimum enable current of 10uA and a maximum enable current of 50uA. The enable current determines the discharge slope of the EL lamp. The minimum enable current equates to the slowest discharge slope and the maximum enable current equates to the fastest discharge slope. The enable resistor internal to the module has been selected as 33kohm. This value has been selected to allow for enable voltages as low as 2.0V (provided V_{enable} is within 10% of V_{supply}). The graph in Figure 1 shows the approximate enable current for various enable resistors at various enable voltages.

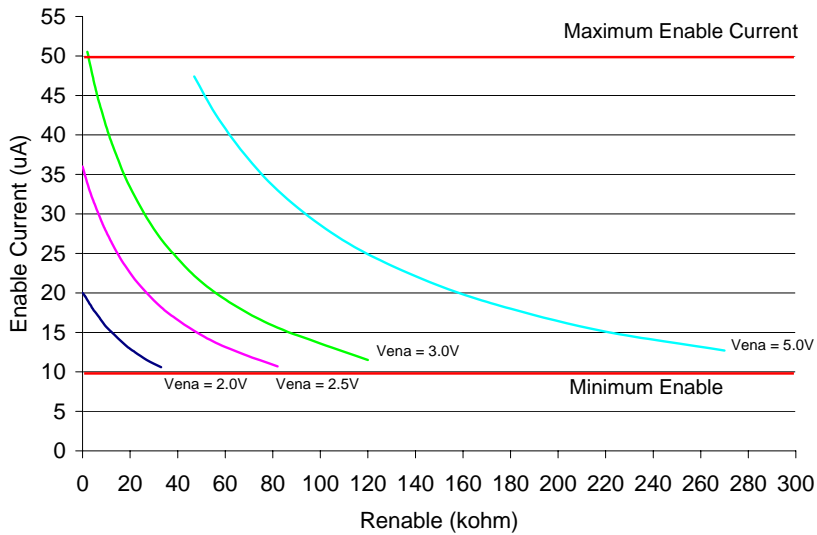
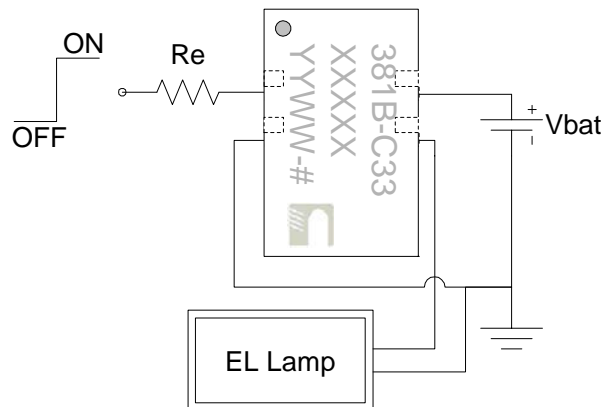

Figure 1: Enable voltage/current selection graph.

In cases such that the enable voltage is greater than 2.0V and the circuit requires a smaller enable current (slower discharge slope), it is recommended that an additional resistor R_e be added externally to the module (See circuit below).



II. Application Testing Recommendations

The following recommendations should be considered when testing the D381B IC module to ensure that the devices are not damaged:

1. When enabled, the D381B IC module output must be connected to a load with minimum 100 ohm series resistance.
2. Do not perform intermittent load test. If an EL lamp is intermittently connected to the D381B IC module, built up charge can be on an EL lamp and will discharge into the Vout pin.
3. The DC input supply voltage (V+) should be applied to pin 10 of the D381B IC module prior to the application of the enable signal high to pin 1. Conversely, when powering off the device, the enable signal must be low prior to the removal of V+ signal.
4. The enable signal must have a fast rising and falling edge, less than a few HF cycles, with no mechanical contact bounce.

III. Storage Recommendations

1. In order to avoid the absorption of moisture, it is recommended to store the module (in bulk or in tape) in a dry box. The module is normally packed in an anti-static envelope.
2. The following environment is recommended for storing:
 - Temperature: 10-30°C (50-60°F)
 - Humidity: 60% maximum relative humidity
3. It is recommended to solder the module as soon as possible after unpacking the anti-static envelope. In cases where module is unpacked, it is recommended that module be stored in a dry box or sealed in an anti-static envelope again and the baking conditions be followed. If the modules in an anti-static envelope are stored over 6 months or if it is opened for more than 48 hours, it is recommended that the modules be baked under the following conditions:
 - 60°C (140°F) for 48 hours or more for tape and reel modules
 - 80°C (176°F) for 8 hours or more for loose modules

IV. Solder Recommendations

The soldering temperature profile for the module is shown below. The recommended melting temperature is 216°C to 220°C (420°F to 428°F). Maximum peak reflow is 250°C (482°F) for 5 seconds.

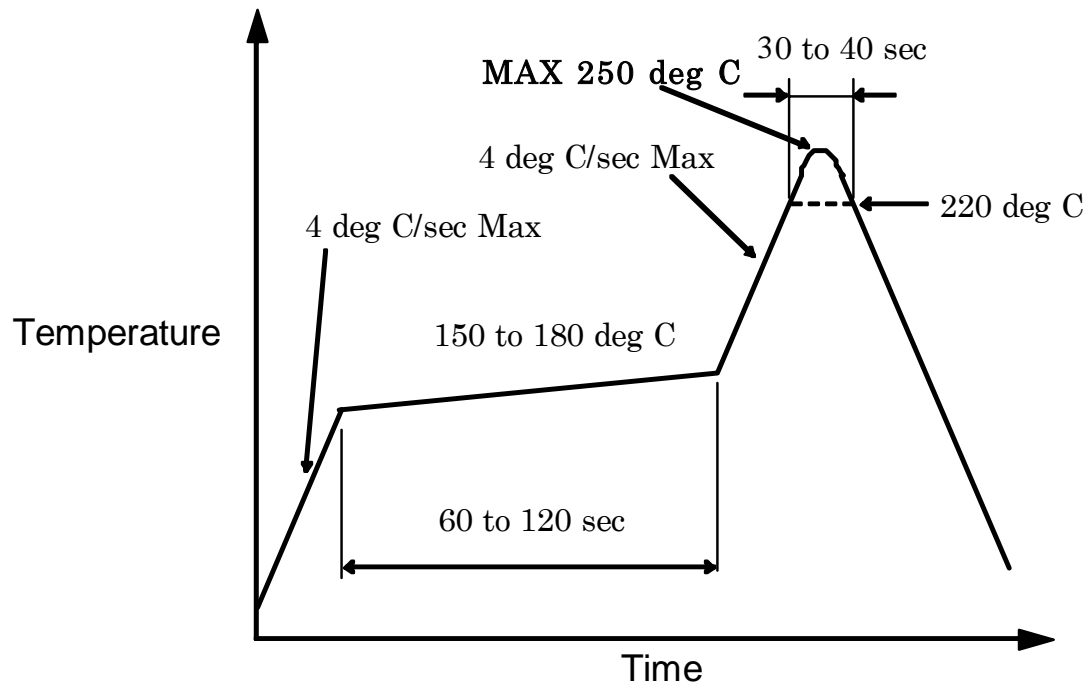

V. Manual Soldering

The use of a soldering iron of less than 25W is recommended. It is recommended that the tip of the soldering iron be kept at or below 300°C (572°F). The maximum soldering time for each pad is 3 seconds and it is recommended that the modules not be handled until the temperature has reached normal room temperature.

D381B IC Design Ideas

Driving Multiple EL Lamps

The D381B module may be used to drive multiple EL lamp segments. An external transistor switching circuit is used to turn each lamp segment on or off independently or simultaneously. A high signal at the corresponding E input will enable the corresponding lamp segment. In this configuration, EL Lamp 1 is always turned on when the IC is enabled. Otherwise, always make sure that at least one lamp segment is selected to be on when the D381B module is enabled.

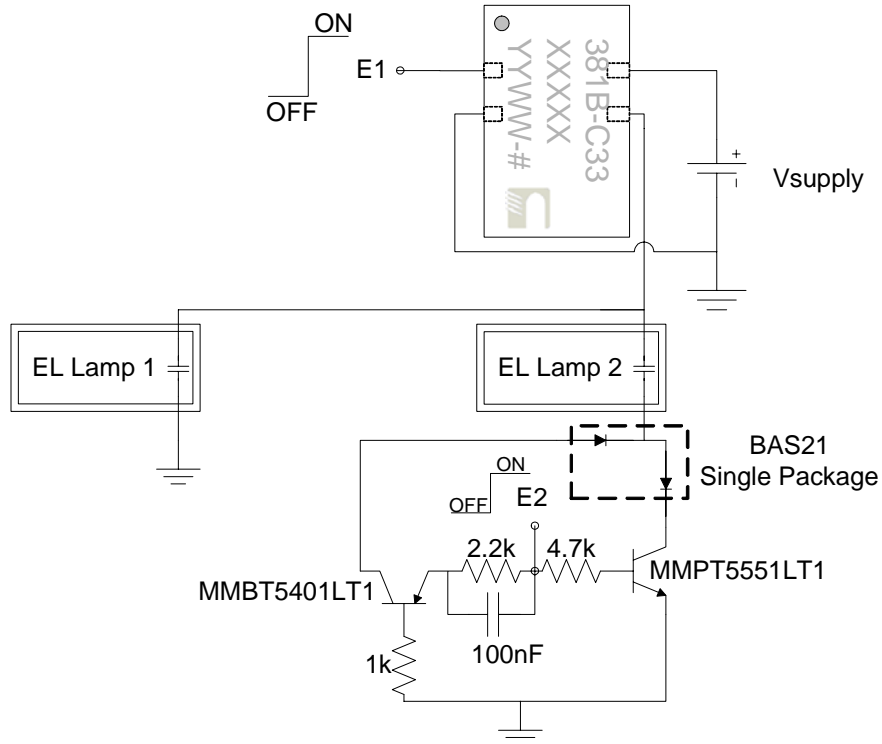

Ordering Information

The D381B IC module is available in a plastic thermal enhanced very thin quad flat package with no protruding leads. A DUREL D381B Module Designer's Kit (1DDD381BB-KM1) provides a vehicle for evaluating. Rogers' engineers provide full support to customers including application retrofits. The QFN body is 5 x 7 x 1.5mm nominal. Tolerances are +/- 0.1mm except for module height which is +0.1mm and -0.15mm.

Module Dimensions

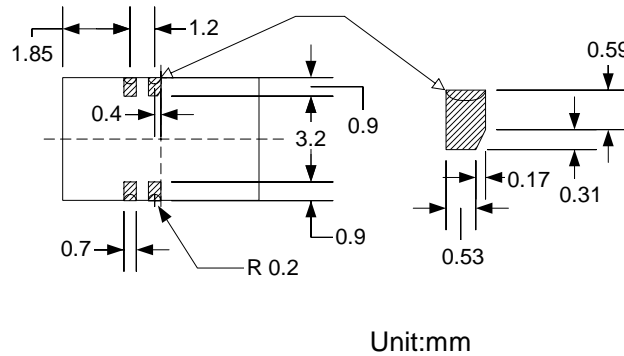
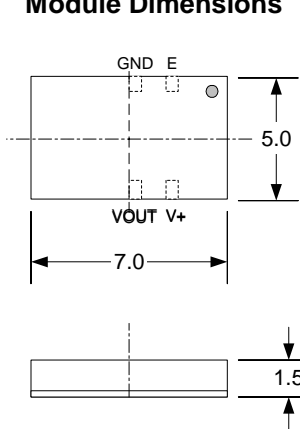

Recommended Pad Layout

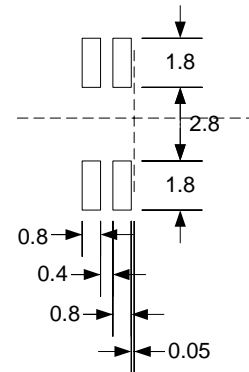

Unit:mm

D381B Module in Tape and Reel: 1DDD381BB-C33

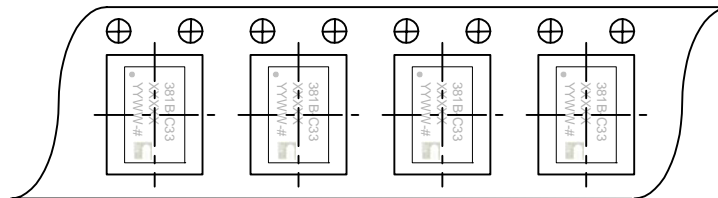

Embossed tape on 330 mm diameter reel.
3000 units per reel. Quantity marked on reel label.

ISO9001:2000, ISO/TS 16949:2002, and ISO14001:1996 Certified

The information contained in this data sheet is intended to assist you in designing with Rogers' EL systems. It is not intended to and does not create any warranties, express or implied, including any warranty of merchantability or fitness for a particular purpose or that the results shown on the data sheet will be achieved by a user for a particular purpose. The user should determine the suitability of Rogers' EL systems for each application.

These EL drivers are covered by one or more of the following U.S. patents: #5,313,141; #5,347,198, #5,677,599; #5,789,870. Corresponding foreign patents are issued and pending.

The world runs better with Rogers.™

DUREL and DFLX are licensed trademarks of Rogers Corporation.

©2005, 2006 Rogers Corporation, Printed in U.S.A.

All Rights Reserved

Revised 4/06 Publication # LIT-I9055 A02