

D356B Electroluminescent Lamp Driver IC

Features

- High Efficiency
- Low Voltage Operation
- Small System Footprint
- Controlled Discharge for Low EMI
- Capacitor or External Clock LF Control
- Available in Lead-Free(Pb-Free) and Green MSOP-8 Package



MSOP-8

Applications

- Watches
- Data Organizer / PDAs
- Pagers
- MP3/GPS/Remote Controls

Rogers DUREL® D356B IC driver is part of a family of highly integrated EL drivers based on Rogers' patented three-port (3P) topology, which offers built-in EMI shielding. This high efficiency device is well suited for backlighting most timepieces and liquid crystal displays for portable electronic applications.

Lamp Driver Specifications:

(Using Standard Test Circuit at Ta=25°C unless otherwise specified.)

Parameter	Symbol	Minimum	Typical	Maximum	Units	Conditions
Standby Current			10	1000	nA	E = GND
Supply Current	I		23	30	mA	E = 3.0V
Enable Current			50	75	uA	E = 3.0V
Output Voltage	Vout	110	135	220	Vpp	
Lamp Frequency	LF	230	310	390	Hz	CLF = 5.0 nF
Inductor Frequency	HF		16		kHz	

Standard Test Circuit

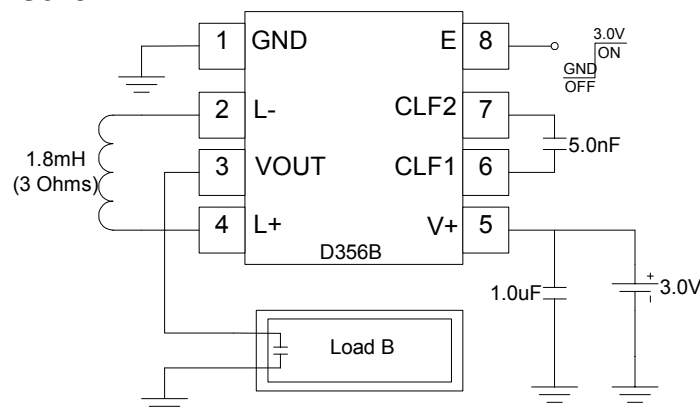

Load B*

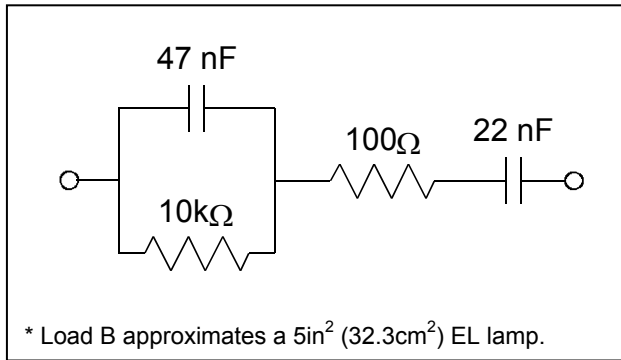

Typical Output Waveform

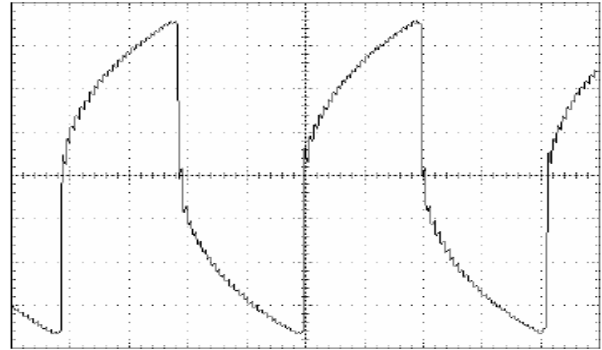

Absolute Maximum Ratings:

Parameter	Symbol	Minimum	Maximum	Unit	Comments
Supply voltage Operating Range Withstand Range	V+	1.0 -0.5	7.0 10.0	V	E = V+ E = GND
Enable voltage Enable on Enable off	E E _{ON} E _{OFF}	-0.5 0.8	(V+) + 0.5 0.6	V	
Output Voltage	V _{OUT}		220	V _{pp}	Peak-to-peak Voltage
CLF Voltage	V _{CLF}	0	(V+) + 0.3	V	External clock input
Operating temperature	T _a	-40	85	°C	
Storage temperature	T _s	-65	150	°C	

Note: The above table reflects stress ratings only. Functional operation of the device at these ratings or any other above those indicated in the specifications is not implied. Exposure to absolute maximum rating conditions for extended periods of time may affect reliability.

Physical Data:

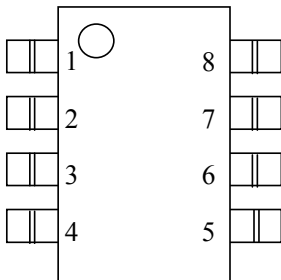

PIN #	NAME	FUNCTION
1	GND	System ground connection
2	L-	Negative input to inductor
3	VOUT	High voltage AC output to lamp
4	L+	Positive input to inductor
5	V+	DC power supply input
6	CLF1	Lamp frequency capacitor/clock input
7	CLF2	Lamp frequency capacitor/clock input
8	E	System enable

Note: Please consult factory for bare die dimensions and bond pad locations.

Typical Performance Characteristics Using Standard Test Circuit

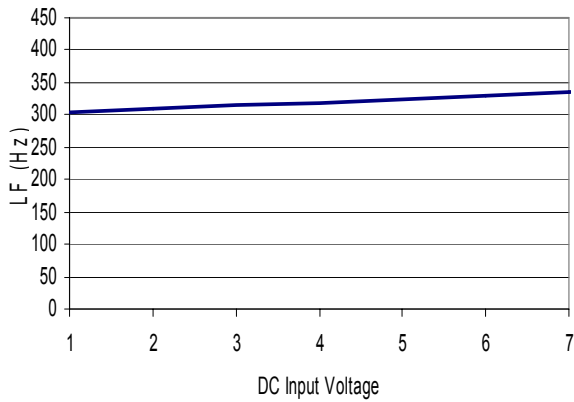

Output Frequency vs. DC Supply Voltage

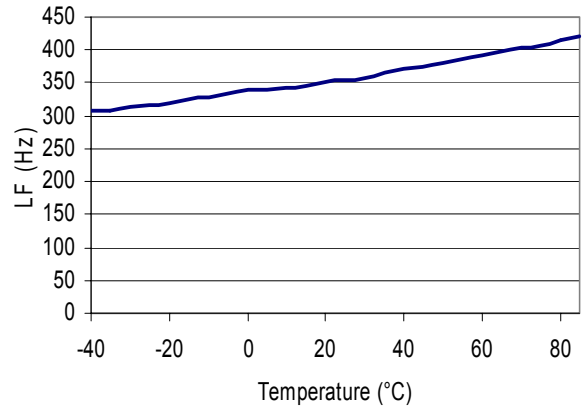

Output Frequency vs. Ambient Temperature

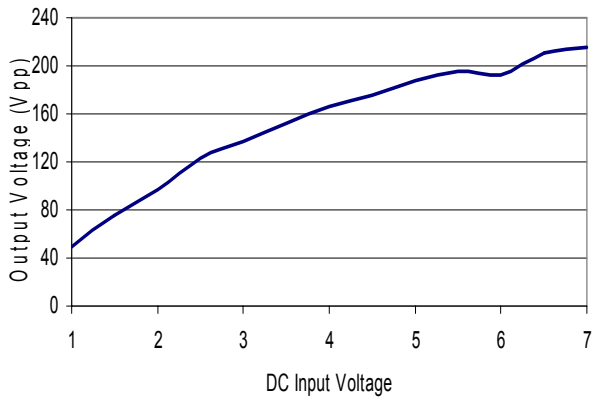

Output Voltage vs. DC Supply Voltage

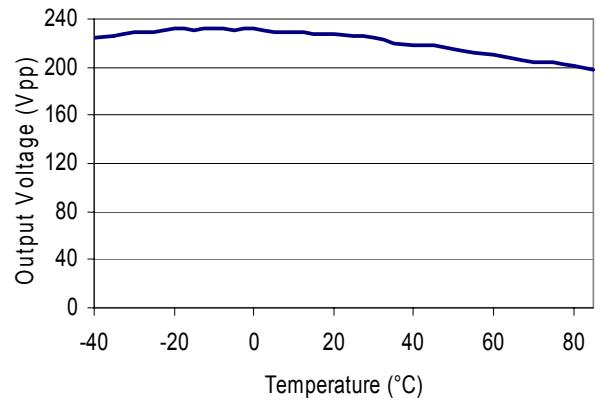

Output Voltage vs. Ambient Temperature

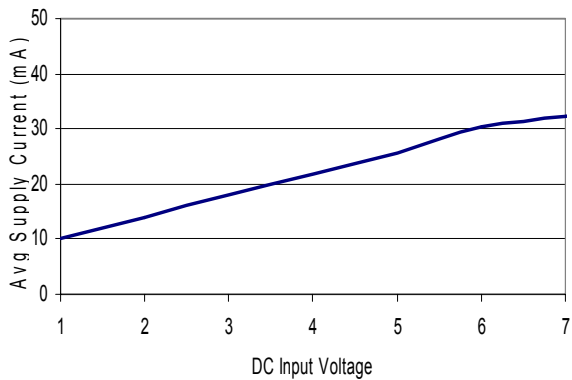

Supply Current vs. DC Supply Voltage

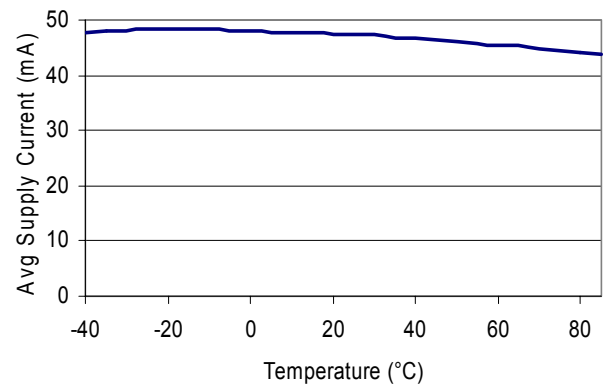

Supply Current vs. Ambient Temperature

Block Diagram of the Inverter Circuitry

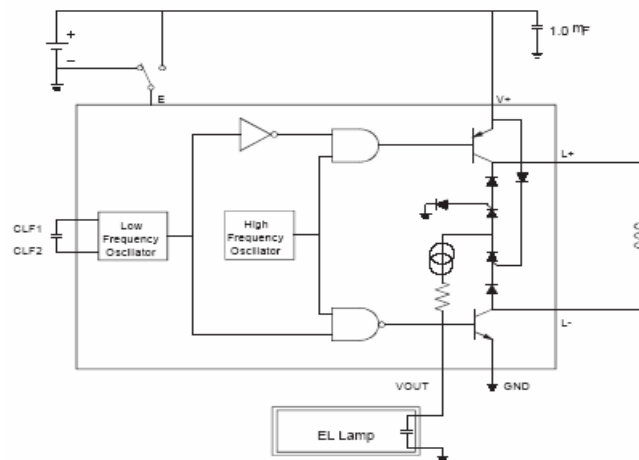

Theory of Operation

Electroluminescent (EL) lamps are essentially capacitors with one transparent electrode and a special phosphor material in the dielectric. The phosphor glows when a strong AC voltage is applied across the EL lamp electrodes. The required AC voltage is typically not present in most systems and must be generated from a low voltage DC source. Rogers developed its patented three-port (3P) switch-mode inverter circuit to convert the available DC supply to an optimal drive signal for high brightness and low-noise EL lamp applications. Rogers 3P topology offers the simplicity of a single DC input, single AC output, and a shared common ground that provides an integrated EMI shielding.

The D356B IC driver drives the EL lamp by repeatedly pumping charge through an external inductor with current from a DC source and discharging into the capacitance of the EL lamp load. With each high frequency (HF) cycle, the voltage on the lamp is increased. At a period specified by the lamp frequency (LF) oscillator, the voltage on the lamp is discharged to ground and the polarity of the inductive charging is reversed. By this means, an alternating positive and negative voltage is developed at the single output lead of the device to one of the electrodes of the EL lamp. The other lamp electrode is commonly connected to a ground plane, which can then be considered as electrical shielding for any underlying circuitry on the application.

The EL driving system is divided into several parts: on-chip logic and control, on-chip high voltage output circuitry, discharge logic circuitry, and off-chip components. The on-chip logic controls the output frequency (LF), as well as the inductor switching frequency (HF), and HF and LF duty cycles. These signals are combined and buffered to regulate the high voltage output circuitry. The output circuitry handles the power through the inductor and delivers the high voltage to the lamp. The selection of off-chip components provides a degree of flexibility to accommodate various lamp sizes, system voltages, and brightness levels. Since a key objective for EL driver systems is to save space and cost, required off-chip components are kept to a minimum.

Rogers provides a D356B IC Driver Designer's Kit, which includes a printed circuit evaluation board intended to aid you in developing an EL lamp driver configuration that meets your requirements using the D356B IC driver. A section on designing with the D356B IC driver is included in this datasheet to serve as a guide to help you select the appropriate external components to complete your D356B IC driver system.

Typical D356B IC driver configurations for driving EL lamps in various applications are shown below. The expected system outputs, such as lamp luminance; lamp output frequency and voltage; and average supply current draw for the various sample configurations are also shown with each respective figure.

Typical D356B IC Driver Configurations

1.5V Analog Watch

Typical Output

Luminance = 3.5 fL (12 cd/m²)

Lamp Frequency = 220 Hz

Supply Current = 10 mA

V_{out} = 178 V_{pp}

Load: 1in² (6.45cm²) DUREL 3 Green EL

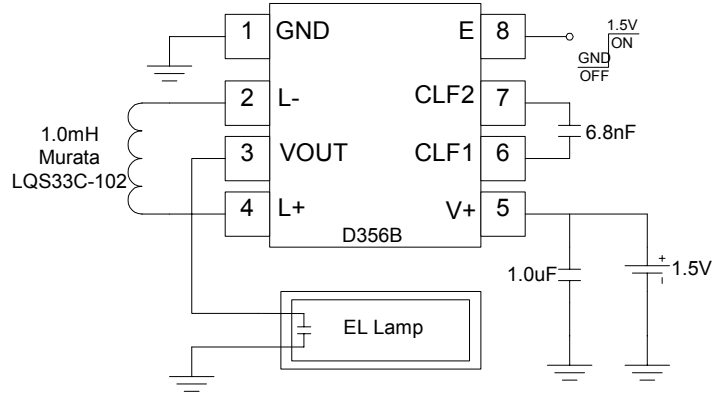

3.0V Handset LCD or Digital Watch

Typical Output

Luminance = 8.6 fL (29.5 cd/m²)

Lamp Frequency = 475 Hz

Supply Current = 14 mA

V_{out} = 208 V_{pp}

Load: 1in² (6.45cm²) DUREL 3 Green EL

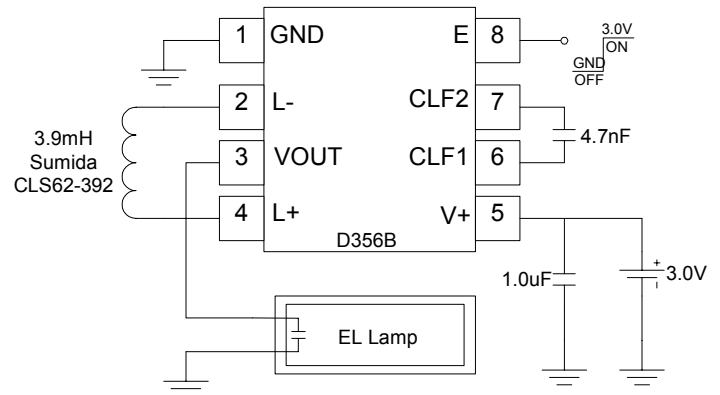

5.0V PDA

Typical Output

Luminance = 7.7 fL (26.4 cd/m²)

Lamp Frequency = 360 Hz

Supply Current = 19 mA

V_{out} = 220 V_{pp}

Load: 4in² (25.8cm²) DUREL 3 Green EL

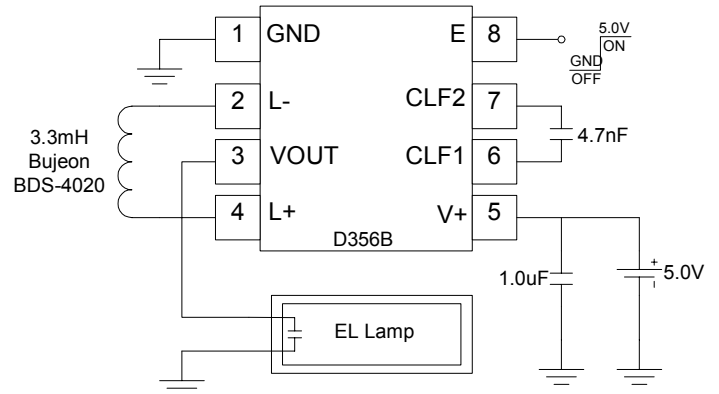

Designing with D356B IC Driver

I. Lamp Frequency Capacitor (CLF) Selection

Selecting the appropriate value of capacitor for the low frequency oscillator (CLF) will set the output frequency of the D356B IC driver. Figure 1 graphically represents the inversely proportional relationship between the CLF capacitor value and the oscillator frequency. In this example at $V^+ = 3.0V$, $LF = 400Hz$ at $3.9nF$.

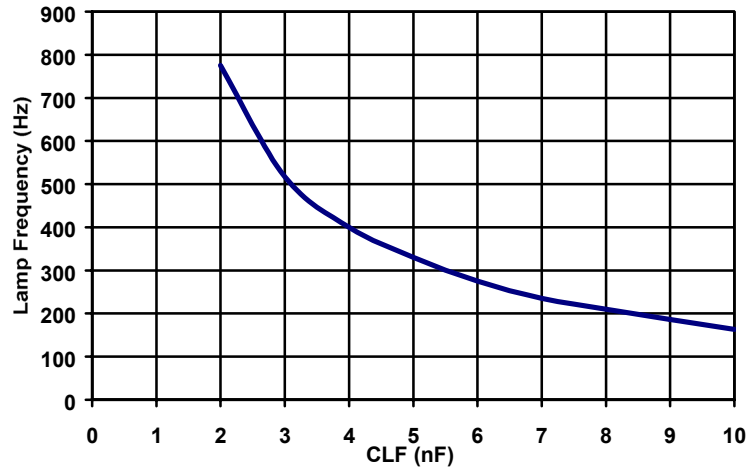

Figure 1: Typical Lamp Frequency vs. CLF Capacitor

Alternatively, the lamp frequency may also be controlled with an external clock signal with a 50% duty cycle. The output lamp frequency will be the same frequency as the input clock signal. For example, if a 250Hz input clock signal is used, the resulting lamp frequency will be 250Hz. The clock signal input voltage should not exceed V^+ .

The selection of the CLF value can also affect the brightness of the EL lamp because of its control of the lamp frequency (LF). Although input voltage and lamp size can change EL lamp frequency as well, LF mainly depends on the CLF value selected or the frequency of the input clock signal to CLF. The luminance of various sizes of a DUREL 3 Blue-green EL lamp driven by a D356B IC driver at $V^+ = 3.0V$ using the same inductor value is shown in Figure 2 with respect to lamp frequency.

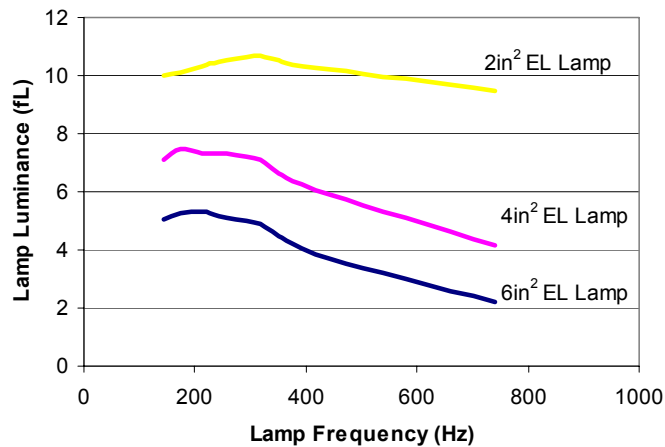

Figure 2: Typical Lamp Luminance vs. Lamp Frequency

II. Inductor (L) Selection

The external inductor (L) selection for a D356B IC driver circuit greatly affects the output capability and current draw of the driver. A careful designer will balance current draw considerations with output performance in the choice of an ideal inductor for a particular application. Figures 3, 4, and 5 show typical brightness and current draw of a D356B IC driver circuit with different inductor values, lamp sizes, and supply voltages while keeping the LF constant. Please note that the DC resistance (DCR) of inductors with the same nominal inductance value may vary with manufacturer and inductor type. Therefore, inductors made by a different manufacturer may yield different outputs, but the trend of the different curves should be similar. Lamp luminance is also a function of lamp size. In each example, a larger lamp will have less luminance with approximately the same current draw.

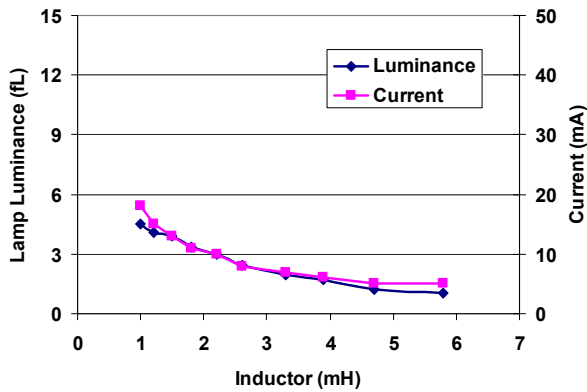

Figure 3: V+=1.5V, 1in² (6.45cm²) EL Lamp

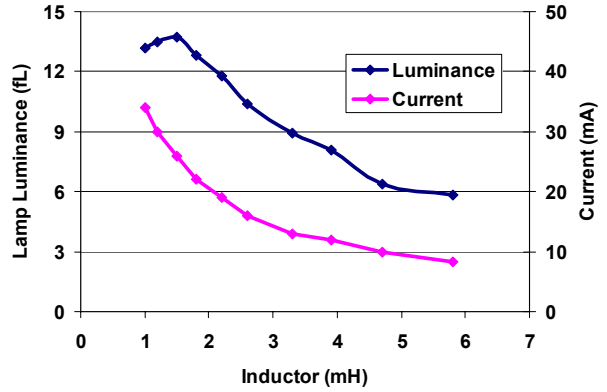

Figure 4: V+=3.0V, 1in² (6.45cm²) EL Lamp

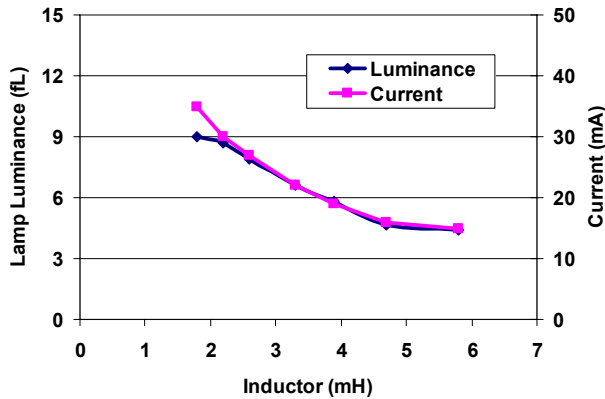
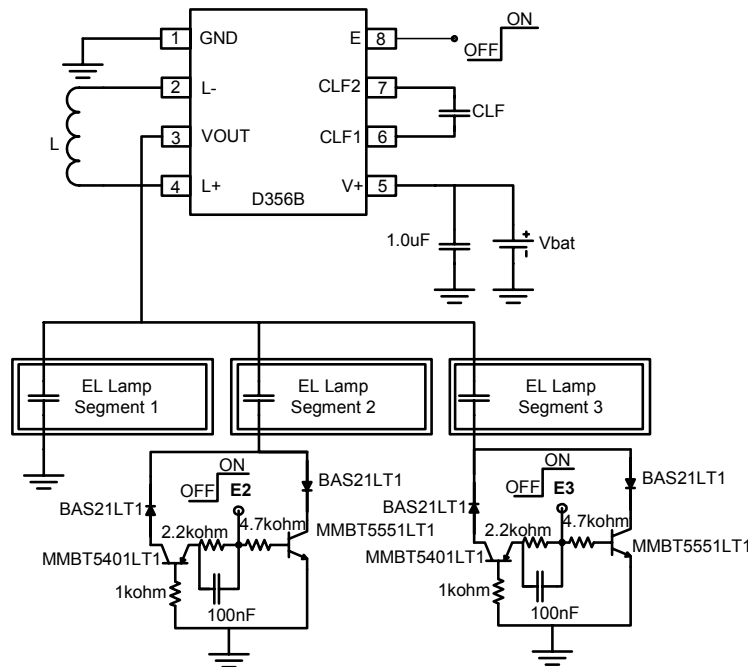

Figure 5: V+=5.0V, 4in² (25.8cm²) EL Lamp

D356B IC Driver Design Ideas

I. Driving Multi-segment Lamps

The D356B IC driver may be used to drive two or more EL lamps or EL lamp areas independently. An external switching circuit can be used to turn each lamp segment on or off. A high signal at the E input for the corresponding EL lamp will power the segment when the IC is enabled. In this example, Segment 1 is always on when the D356B IC driver is enabled. Otherwise, always make sure that at least one segment is switched on when the D356B IC driver is activated.



II. Two-Level Dimming

Toggle switching between two different EL lamp brightness levels may be achieved, as captioned in the circuit shown below. When DIM is low, the external PNP transistor is saturated and the EL lamp runs at full brightness. When DIM is high, the external PNP turns off and the 47ohm resistor reduces the voltage at (V+) and dims the EL lamp.

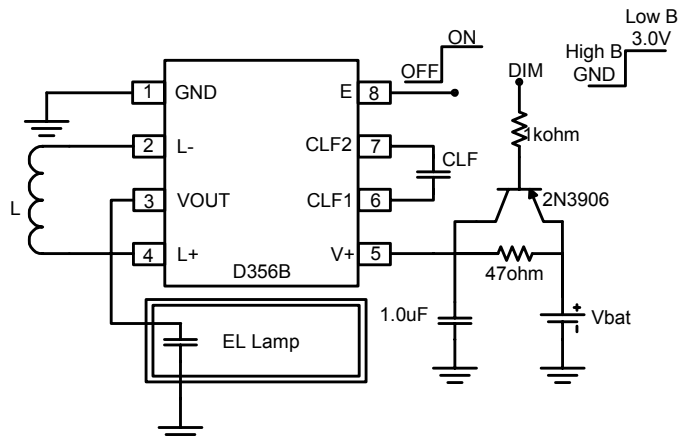

III. Lamp Frequency Control with an External Clock Signal

An external clock signal with a 50% duty cycle may be used to control the EL lamp frequency (LF). This technique allows the designer flexibility to synchronize the EL IC driver with other elements in the application. The output lamp frequency will be the same frequency as the input clock signal. For example, if a 250Hz input clock signal is used, the resulting lamp frequency will be 250Hz. The clock signal voltage should not exceed V_{+} .

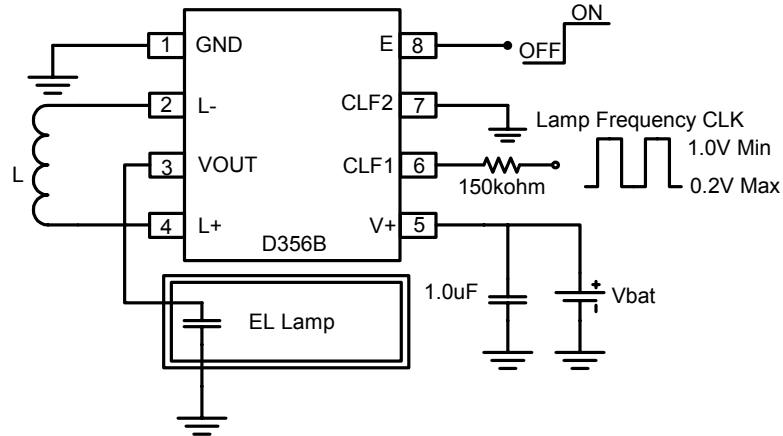

IV. EL Lamp Brightness Regulation

Regulating the DC supply input voltage to the D356B IC driver will result in a constant brightness level from the EL lamp, regardless of battery voltage. In this example, a voltage regulator is used.

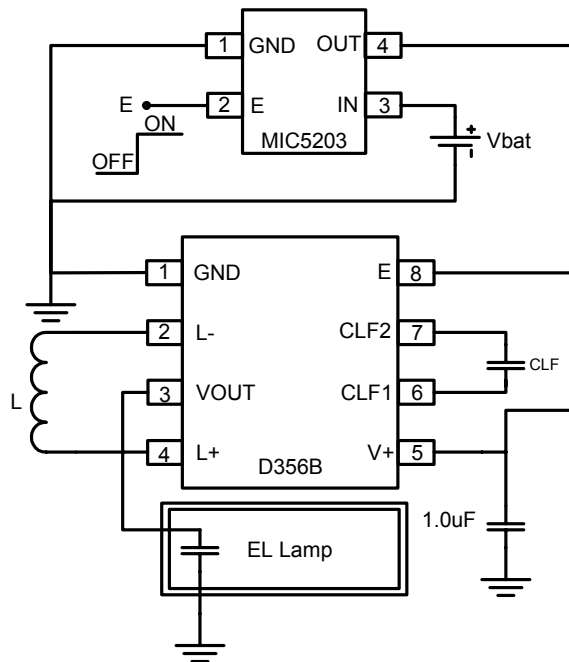

V. High EL Brightness Through Supply Voltage Doubling (Option 1)

Maximum brightness from a D356B IC driver is achieved at relatively high supply voltages (>3.0V). An external voltage boost circuit may be used to increase the voltage supplied to the D356B IC driver. In the following diagram, the LM2665 boost converter is used to double the voltage supplied to the D356B IC driver. This can produce about twice the brightness of the D356B IC driver alone.

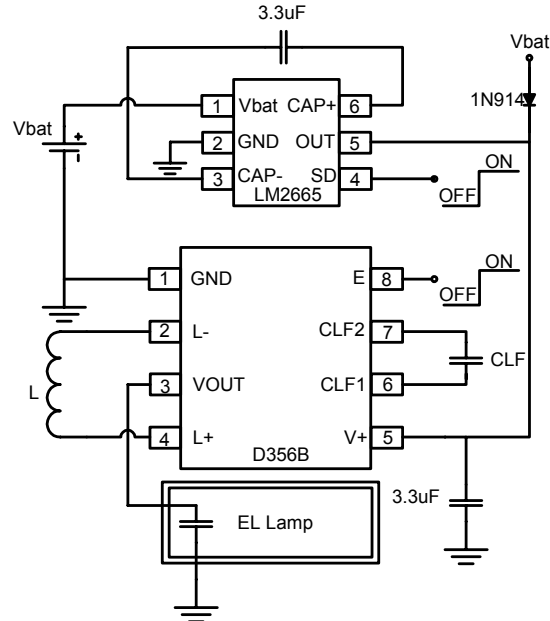

VI. High EL Brightness Through Supply Voltage Doubling (Option 2)

In many cases, a resistor may replace the diode shown in the previous configuration. The diode is used by the LM2665 converter during startup (see LM2665 converter datasheet). The circuit configuration shown below ensures that the LM2665 converter starts properly before the D356B IC driver is turned on.

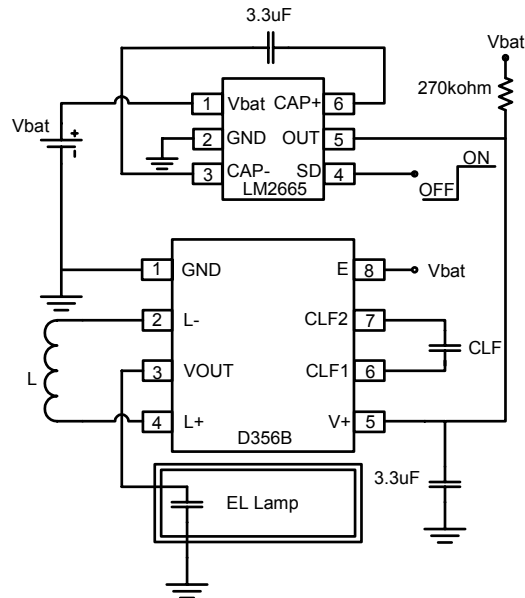

VII. High EL Brightness with Parallel D356B IC Driver (Option 1)

Two or more D356B IC drivers may be operated in parallel to increase the brightness of the EL lamp by 50-100%. In this example, an external clock signal with 50% duty cycle is needed to synchronously drive both D356B IC drivers. The clock signal voltage should not exceed V+.

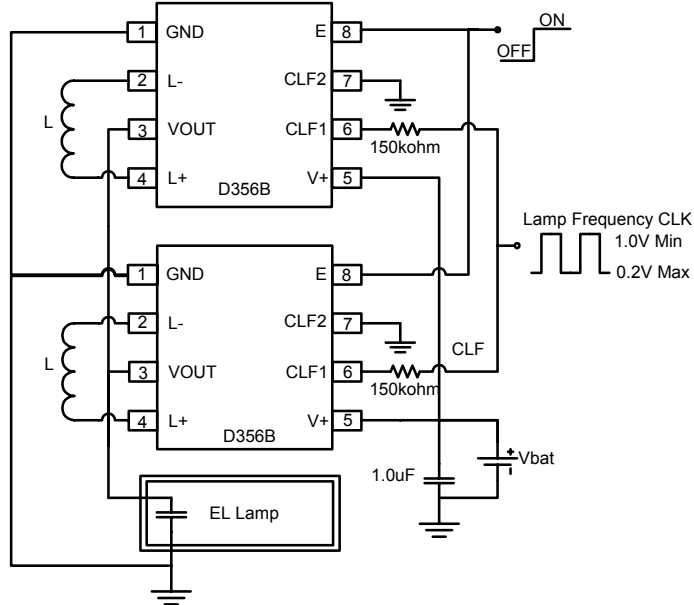

VIII. High EL Brightness with Parallel D356B IC Driver (Option 2)

Two or more D356B IC drivers may be operated in parallel to increase the brightness of the EL lamp by 50-100%. In this diagram, two D356B IC drivers are operating synchronously using their internal oscillators. The lamp frequency is controlled by a shared CLF capacitor.

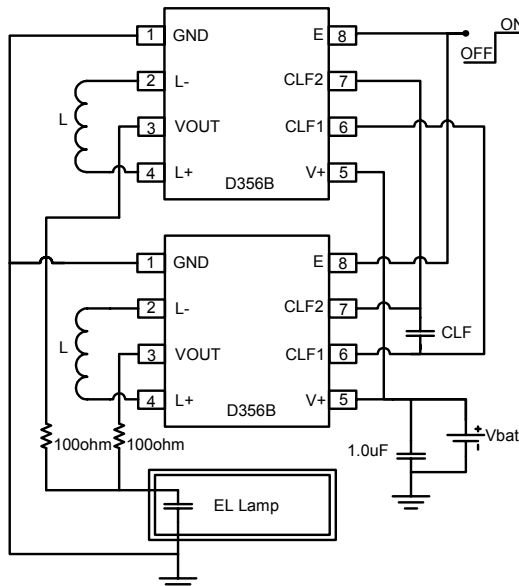

IX. Solder Re-Flow Recommendations

Classification Reflow Profiles

Profile Feature	Sn-Pb Eutectic Assembly	Pb-Free Assembly
Average ramp-up rate (T_L to T_P)	3°C/second max.	3°C/second max.
Preheat -Temperature Min (T_{smin}) -Temperature Max (T_{smax}) -Time (min to max) (ts)	100°C 150°C 60-120 seconds	150°C 200°C 60-180 seconds
T_{smax} to T_L -Ramp-up Rate		3°C/second max.
Time maintained above: Temperature (T_L) -Time (T_L)	183°C 60-150 seconds	217°C 60-150 seconds
Peak Temperature (T_P)	240 +0/-5°C	250 +0/-5°C
Time within 5°C of actual Peak Temperature (T_P)	10-30 seconds	20-40 seconds
Ramp-down Rate Time 25°C to Peak	6°C/second max.	6°C/second max.
Temperature	6 minutes max.	8 minutes max.

Note: All temperatures refer to topside of the package, measured on the package body surface and to IPC/JEDEC J-STD-020B standards.

IPC/JEDEC J-STD-020B

July 2002

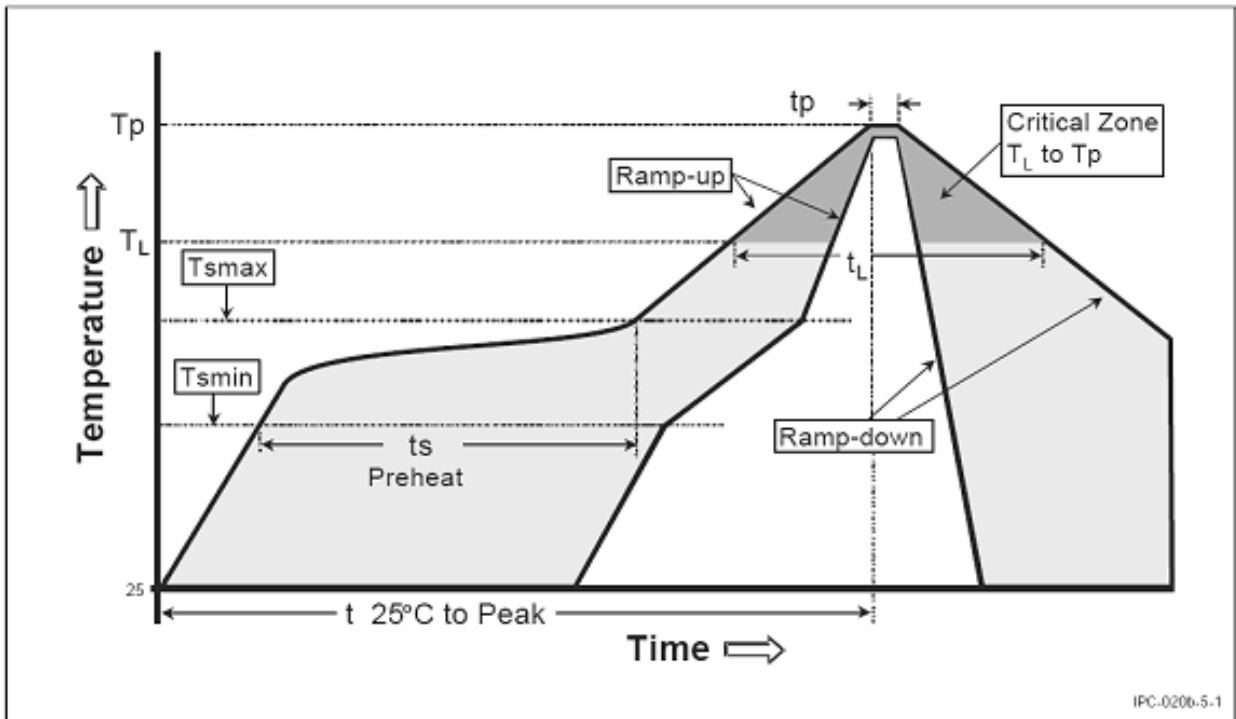
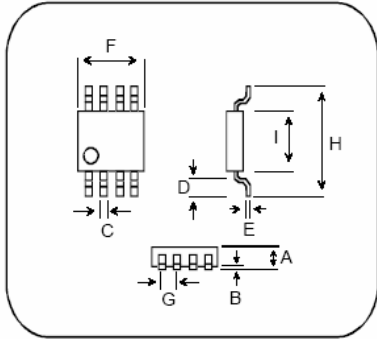

Figure 5-1 Classification Reflow Profile

Ordering Information

The D356B IC driver is available as bare die in probed wafer form or in die tray, and in standard or Pb-free MSOP-8 package per tube or per tape and reel. A D356B IC Driver Designer's Kit (1DDD356BB-K01) provides a vehicle for evaluating and identifying the optimum component values for any particular application using D356B IC driver. Rogers engineers also provide full support to customers, including specialized circuit optimization and application retrofits.



	MSOP-8					
	Min		Typical		Max	
	mm	in	mm	in	mm	in
A	0.94	0.037	1.02	0.040	1.09	0.043
B	0.05	0.002	0.10	0.004	0.15	0.006
C	0.20	0.008	0.33	0.013	0.46	0.018
D	0.41	0.016	0.53	0.021	0.65	0.026
E	0.13	0.005	0.18	0.007	0.23	0.009
F	2.84	0.112	3.00	0.118	3.15	0.124
G	0.43	0.017	0.65	0.026	0.83	0.033
H	4.70	0.185	4.90	0.193	5.11	0.201
I	2.84	0.112	3.00	0.118	3.25	0.128

RECOMMENDED PAD LAYOUT

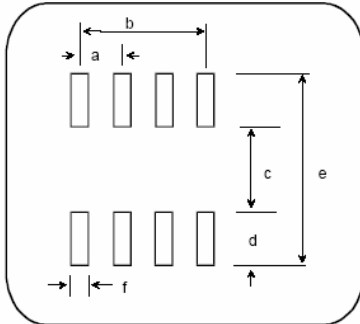

	MSOP-8 PAD LAYOUT					
	Min		Typical		Max	
	mm	in	mm	in	mm	in
a	0.60	0.024	0.6	0.026	0.70	0.028
b	1.90	0.075	1.9	0.077	2.00	0.079
c	3.3	0.130			3.45	0.136
d	0.89	0.035	0.9	0.038	1.05	0.041
e	5.26	0.207			5.41	0.213
f	0.41	0.016	0.4	0.018	0.51	0.020

MSOPs in Tape & Reel:
1DDD356BB-M02
1DDD356BB-NL2

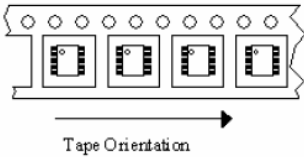

Embossed tape on 360mm diameter reel per EIA-481-2.
 2500 units per reel. Quantity marked on reel label

1DDD356BB-M02

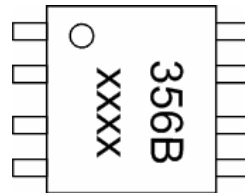

Standard MSOP-8

1DDD356BB-NL2

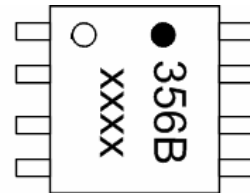

Pb-Free Green MSOP-8

ISO9001:2000, ISO/TS 16949:2002, and ISO14001:1996 Certified

The information contained in this data sheet is intended to assist you in designing with Rogers' EL systems. It is not intended to and does not create any warranties, express or implied, including any warranty of merchantability or fitness for a particular purpose or that the results shown on the data sheet will be achieved by a user for a particular purpose. The user should determine the suitability of Rogers' EL systems for each application.

These EL drivers are covered by one or more of the following U.S. patents: #5,313,141; # 5,347,198; #5,677,599; #5,789,870; #6,043,610. Corresponding foreign patents are issued and pending.

The world runs better with Rogers. Is a licensed trademark of Rogers Corporation.

DUREL is a licensed trademark of Rogers Corporation.

©2001, 2004, 2005 Rogers Corporation, Printed in U.S.A.

All Rights Reserved

Revised 4/05 Publication # LIT-19039A03

The world runs better with Rogers.™