

**Application Note**

## D306A Electroluminescent Lamp Driver with Microcontroller

### Features:

- 2.0 – 12.0V<sub>DC</sub> Battery Operation
- High AC Voltage Output To 400V<sub>pp</sub>
- Very Low Standby Current
- Flexible Wave-shaping Capability
- QFN-16 Square Body with Heat Slug
- QFN-16 Package is a Lead-free (Pb-free) Green.

### Applications:

- Large Area LCD with EL lamp backlight
- Signage Backlight
- Graphics Display Lighting
- Automotive Interior Lighting

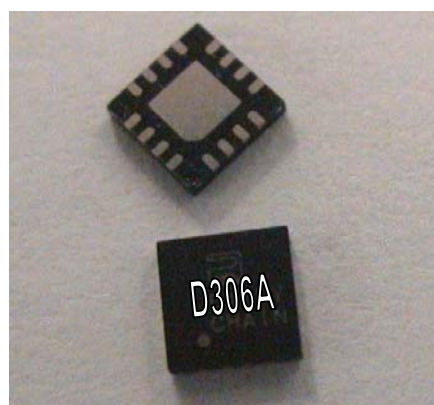

**QFN – 16 with Heat Slug**

## Introduction

Rogers DUREL® D306A IC driver is a high-power IC inverter intended for driving electroluminescent (EL) lamps as large as 180 cm<sup>2</sup>. The D306A IC is equipped with many control functions (including wave-shaping programmability for minimizing audible noise) and features that allow for component cost savings, precision control of frequencies, and stability of lamp color over wide temperature extremes.

In conjunction with a microcontroller (CY8C24143-24PI PSoC), the D306A IC driver application is augmented with the following functions:

- Dimming Control
- Life Compensation
- Power Supply Monitoring
- Elapsed Time Algorithm
- Data Storage in Flash
- Low-Voltage Detection
- Watch-Dog Timer

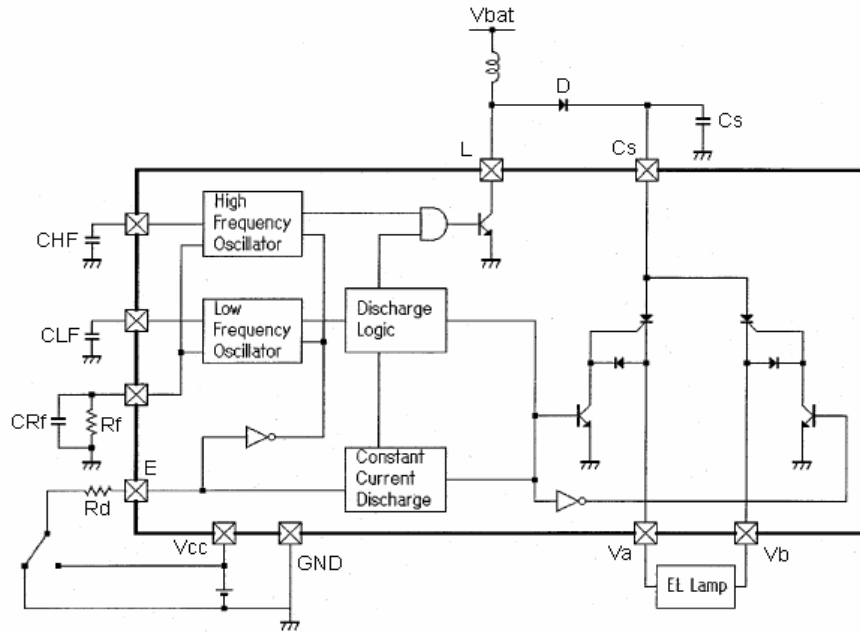

## Theory of Operation

Electroluminescent lamps are essentially capacitors with one transparent electrode and a special phosphor material in the dielectric. The phosphor glows when a strong AC voltage is applied across the EL lamp electrodes. The required AC voltage is typically not present in most systems and must be generated from a low voltage DC source.

The D306A IC inverter drives the EL lamp by using a switching transistor to repeatedly charge an external inductor and discharge it to the high voltage capacitor  $C_s$ . The discharging causes the voltage at  $C_s$  to continually increase. When the voltage at  $C_s$  reaches a nominal value, the switching transistor is turned off. The internal circuitry uses the H-bridge technology, using both electrodes to drive the EL lamp. One of the outputs,  $V_a$  or  $V_b$ , is used to discharge  $C_s$  into the EL lamp during the first half of the low frequency (LF) cycle. By alternating the state of the H-bridge, the other output is used to charge the EL lamp during the second half of the LF cycle. The alternating states make it possible to achieve  $400 V_{MAX}$  peak-to-peak across the EL lamp.

The EL driving system is divided into several parts: on-chip logic control, on-chip high voltage output circuitry, on-chip discharge logic circuitry, and off-chip components. The on-chip logic controls the lamp operating frequency (LF) and the inductor switching frequency (HF). These signals are used to drive the high voltage output circuitry (H-bridge) by delivering the power from the inductor to the lamp. The integrated discharge logic circuitry uses a patented wave-shaping technique for reducing audible noise from an EL lamp. Changing the  $R_d$  value changes the slope of the linear discharge as well as the shape of the waveform. The off-chip component selection provides a degree of flexibility to accommodate various lamp sizes, system voltages, and brightness levels.

The block diagram in Figure 1 below illustrates the theory of operation of D306A. In conjunction with the microcontroller the  $CR_f$  and  $R_f$  components are not needed and are simply replaced by the voltage  $V_{cc}$ . The capacitors  $CHF$  and  $CLF$  are also not needed and are replaced by two different pulse width modulators (PWM).

## Absolute Maximum Ratings

Parameter	Symbol	Minimum	Maximum	Unit	Comments
Supply Voltage Operating Range Withstand Range	Vbat	2.0 -0.5	12 16	V	E = Vcc E = GND
Logic Drive Voltage Operating Range Withstand Range	Vcc	2 -0.5	5 6	V	E = Vcc E = GND
Enable voltage	E	-0.5	V <sub>CC</sub> +0.5	V	
Vout	Va-Vb		410	Vpp	E = Vcc
Operating temperature	T <sub>a</sub> T <sub>j</sub>	-40	85 125	°C °C	Ambient Junction
Average Thermal Resistance	Θ <sub>ja</sub> Θ <sub>jc</sub>		40.0 5.3	°C/W °C/W	Junction to Ambient Junction to case
Storage temperature	T <sub>s</sub>	-55	150	°C	

\*At a given ambient temperature, the maximum power rating can be calculated with the following equation:  $T_j = P(\Theta_{ja}) + T_a$ .

Note: The above are stress ratings only. Functional operation of the device at these ratings or any other above those indicated in the specifications is not implied. Exposure to absolute maximum rating conditions for extended periods of time may affect reliability.

## Designing with D306A IC Driver

There are many variables which can be optimized to achieve the desired performance for specific applications. The luminance of the EL lamp is a function of the output voltage applied to the lamp by the IC, the frequency at which the voltage is applied, the lamp material properties, and the lamp size. Rogers offers the following component selection aids and microcontroller tips to help the designer select the optimum circuit configuration.

### I. Inductor (L) Selection

The inductor value has a large impact on the output brightness and current consumption of the driver. Figure 2 shows typical brightness and current draw of a D306A IC driver with different inductor values. Please note that the DC resistance (DCR) and current rating of inductors with the same inductance value may vary with manufacturer and inductor type. Thus, inductors made by a different manufacturer may yield different outputs, but the trend of the different curves should be similar. This curve is intended to give the designer a relative scale from which to optimize specific applications. Absolute measurements may vary depending upon the type and brand of other external components selected.

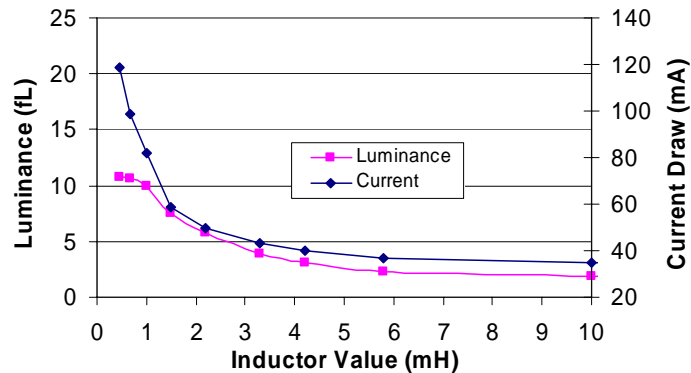

Figure 2. Luminance and current vs. inductor value.

Conditions: V<sub>cc</sub> = 5V, V<sub>bat</sub> = 6.5V, 5.96 in<sup>2</sup> (38.4578cm<sup>2</sup>) RBC 665 EL Lamp

## **II. Wave-Shape Selection**

The D306A EL driver IC uses a patented wave-shaping technique for reducing audible noise from an EL lamp. The slope of the discharge section of the output waveform may be adjusted by selecting a proper value for the wave-shape discharge resistor ( $R_d$ ) in series with the E pin input. The optimal discharge level for an application depends on the lamp size, lamp brightness, and application conditions. To ensure that the D306A IC driver is configured optimally, various discharge levels should be evaluated. In many cases, lower discharge levels may result in lower audible noise from the EL lamp. The recommended typical value for  $R_d$  is  $10k\Omega$ .

## **III. Storage Capacitor ( $C_s$ ) Selection**

The  $C_s$  capacitor is used to store the energy transferred from the inductor before discharging the energy to the EL lamp.  $C_s$  values can range from  $1.5nF$  to  $4.7nF$  and must have minimum 200V rating. In general, the  $C_s$  value does not have a large affect on the output of the device. The typical  $C_s$  capacitor recommendation is  $2.2nF$  with 200V rating.

## **IV. Fast Recovery Diode**

Energy stored by the coil is eventually forced through the external diode to power the switched H-bridge network. A fast recovery diode, such as BAS21, is recommended for this function for optimum operation.

## **V. Optional Zener Diodes**

The D306A IC EL driver circuit should be designed such that the output voltage of the device does not exceed the maximum rated value of  $400V_{pp}$ . Operating the D306A IC driver above this rating can cause irreversible damage to the device. This condition is most likely in applications, such as in automotive instrument clusters, where the supply voltage ( $V_{bat}$ ) is higher than  $6.0V$  and can generate output voltage greater than  $400V_{pp}$ . Extreme temperature change can also cause the output voltage to exceed the maximum rating, especially when the nominal operating voltage of the device is close to the maximum limit at room temperature. A 200V zener diode connected in parallel to the  $C_s$  capacitor and ground of the D306A IC driver is recommended to limit the device output to less than  $400V_{pp}$ . This component is optional and may be eliminated in applications which are known to function only within safe operating conditions.

The D306A IC driver should be designed such that it is never tested or operated without an EL lamp or equivalent capacitive load. In situations where there is a risk that power may be applied to D306A IC driver without a load, 200 volt zener diode should be added to  $V_a$  and  $V_b$  pins. A schematic is shown in Figure 3 which illustrates the use of these diodes.



# D306A IC Driver Design Ideas using PSoC

## I. Controlling Output Frequency Using External Clock Signals

External clock signals may be used to control the D306A IC driver oscillator frequencies instead of adding external passive components. When clocking, signals provide both the inductor charging (HF) and lamp output (LF) oscillator frequencies to drive the D306A integrated circuit, the CLF, CHF, Rf, and CRf components are no longer required. A sample configuration demonstrating this cost-saving option is shown below in Figure 4.

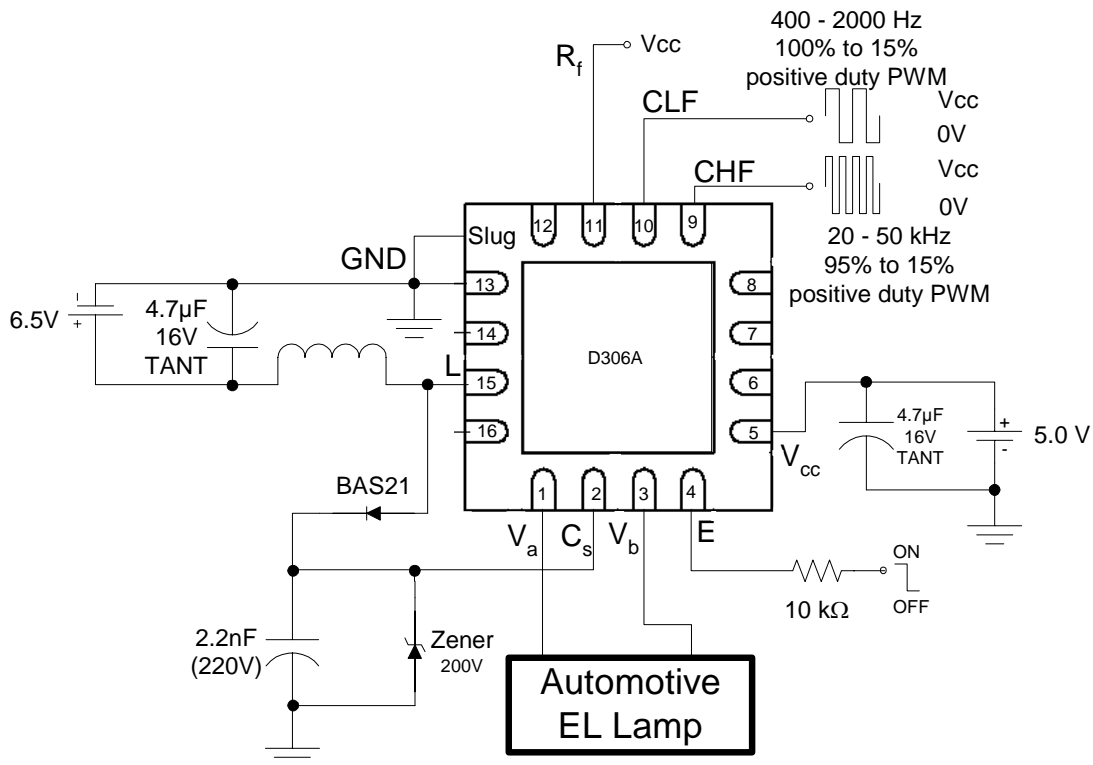

Figure 4. Example of D306A with PWM inputs

In this configuration, the lamp output frequency is controlled by the signal applied to the CLF pin. An internal divider network in the IC divides the frequency of the LF input signal by two. Thus, to get a 400Hz AC output waveform to drive the EL lamp, an 800Hz square-wave input signal should be connected to the CLF pin. Input clocking frequencies may range from 400 Hz to 2000 Hz, with 15-20% positive duty cycle for optimum brightness.

The high frequency oscillator that determines inductor charging frequency is controlled above by a digital AC signal into the CHF pin. The HF clock signal frequency may range from 20kHz – 50kHz, with 15-20% positive duty cycle for optimum lamp intensity.

## II. Controlling EL Brightness through Clock Pulse Width Modulation (Option 1)

Pulse-width modulation of the external LF input signal may be used to regulate the brightness of the EL lamp. Figures 5, 6, and 7 on the following page demonstrate examples of the D306A IC driver output waveform with pulse width modulation of the LF input signal. As the positive duty cycle of the LF input signal is increased from 15% to 100%, the charging period of the output waveform decreases, and the peak voltage of the output waveform also decreases towards zero output. Therefore, incremental dimming occurs as a result of the wave-shaping changes. This scheme may also be used inversely to regulate lamp brightness over the life of the battery or to compensate for lamp aging. Figure 8 shows a typical dimming curve with this technique. Operation at duty cycles lower than 10% is not recommended. Clocking frequency can range from 400Hz to 2000Hz.

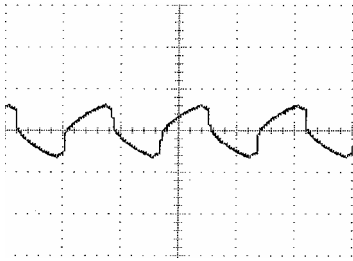

Figure 5: LF Input Duty Cycle = +15%

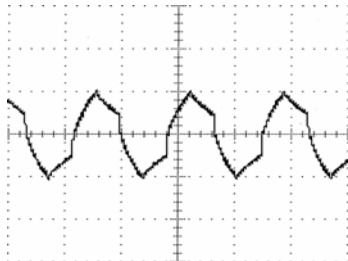

Figure 6: LF Input Duty Cycle = +50%

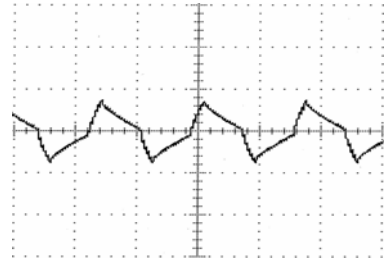

Figure 7: LF Input Duty Cycle = +75%

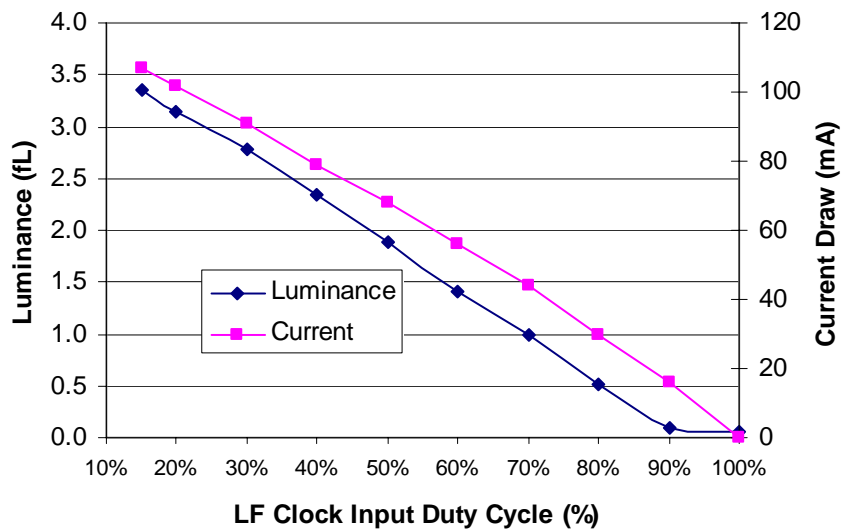

Figure 8: Dimming through LF Clock Input Duty Cycle

### III. Controlling EL Brightness through Clock Pulse-Width Modulation (Option 2)

Pulse-width modulation of the external HF input signal also may be used to regulate the brightness of the EL lamp. As the positive duty cycle of the HF input signal is increased from 10% to 95%, the peak voltage of the output waveform decreases incrementally to zero output as the inductor charging period is affected by the HF duty cycle. Lamp dimming is thus achieved with pulse-width modulation of the HF input signal to the D306A IC driver. This scheme may also be used inversely to regulate lamp brightness over the life of the battery or to compensate for lamp aging. Figure 9 shows a typical dimming curve with this technique. The recommended HF duty cycle range is from 10% to 95%. Clocking frequency can range from 20kHz to 50kHz.

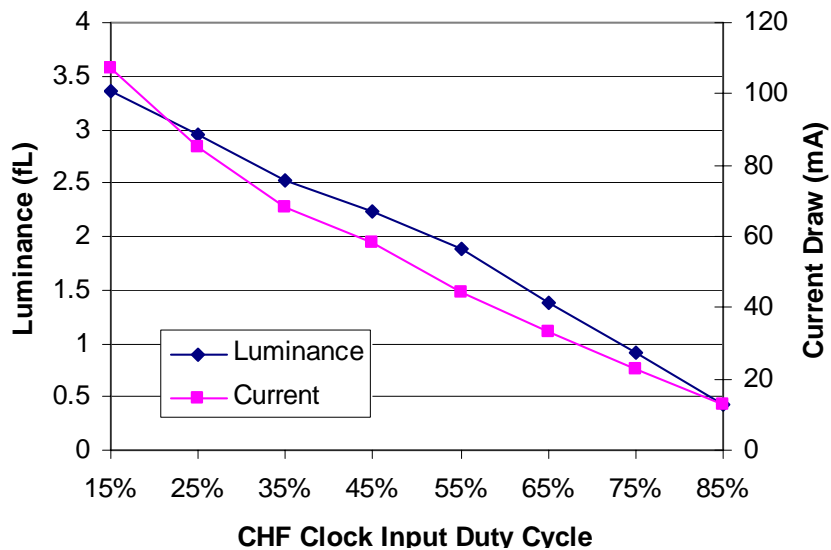

Figure 9: Dimming through HF Clock Input Duty Cycle

### IV. Controlling EL Life and Brightness through Clock Pulse-Width Modulation using PSoC

Pulse-width modulation of the external HF and LF signals may be used to control life compensation and brightness of the EL lamp. EL lamps gradually dim with age and, therefore, may need more power as time progresses to extend the usable life. Also, some applications may require EL lamp brightness control for dimming. The PSoC device provides for both these needs through a real-time clock and PWM variations. Figure 10 shows the circuit which uses Integrated Circuit U2 (CY8C24143-24PI) to accomplish life compensation and controls EL dimming. Refer to Cypress Microsystems "PSoC as an Electroluminescent Backlight Display Controller" for design notes.

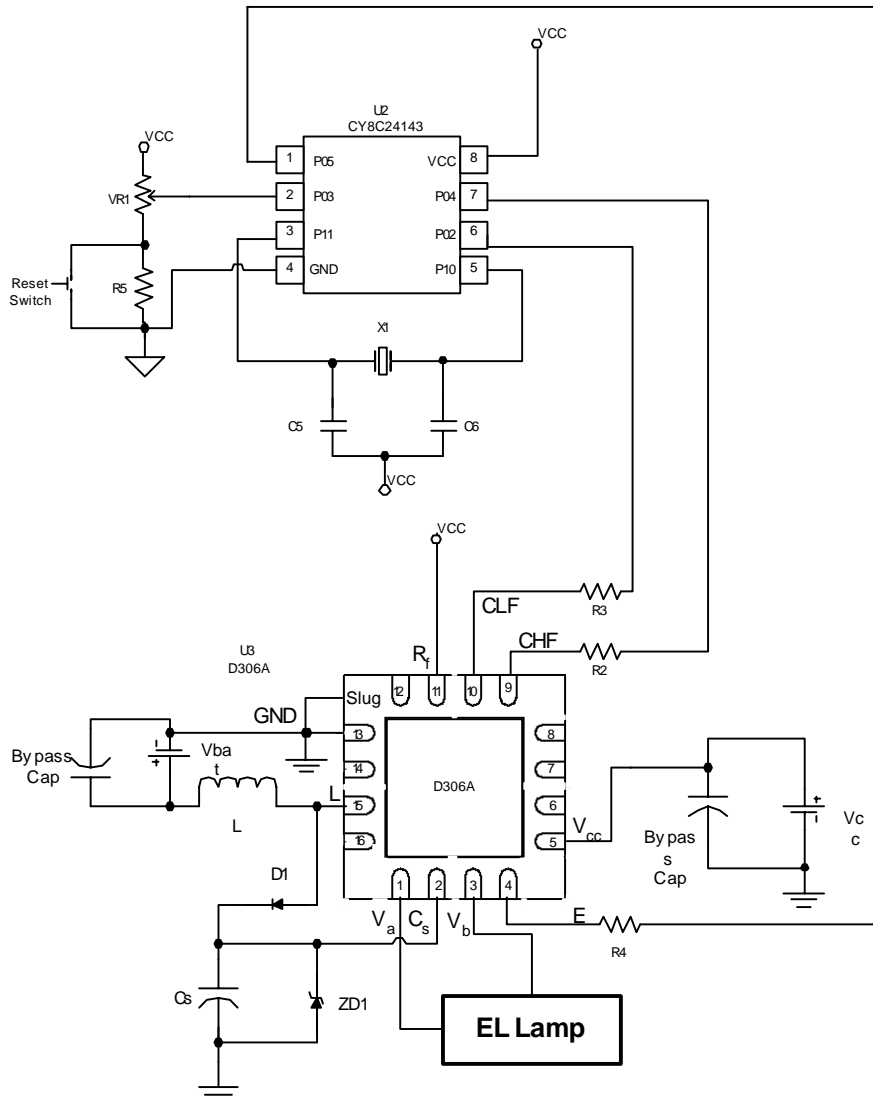

Figure 10. D306A with PSoc Configuration

**ISO 9001: 2000, ISO/TS 16949:2002, and ISO 14001: 1996 Certified**

The information contained in this data sheet is intended to assist you in designing with Rogers' EL systems. It is not intended to and does not create any warranties, express or implied, including any warranty of merchantability or fitness for a particular purpose or that the results shown on the data sheet will be achieved by a user for a particular purpose. The user should determine the suitability of Rogers' EL systems for each application.

These EL drivers are covered by one or more of the following us patents: #5,313,141; #5,789,870; #6,297,597. B1. Corresponding foreign patents are issued and pending.

**The world runs better with Rogers.™**

DUREL is a licensed trademark of Rogers Corporation.  
 ©2005 Rogers Corporation, Printed in USA  
 All Rights Reserved  
**Publication # Lit-I9060A01**